

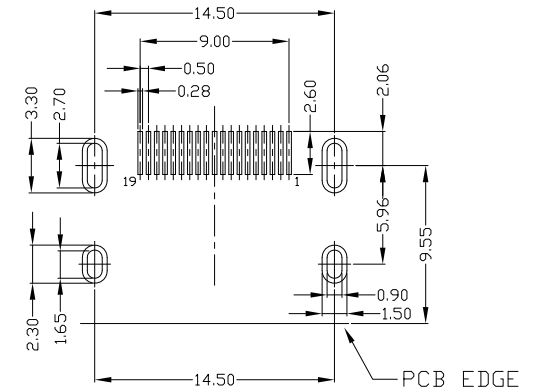

RoHS
Compliant
2002/95/EC

Halogen Free

REV.	ECN. NO.	APPD.

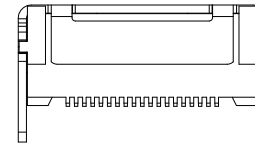
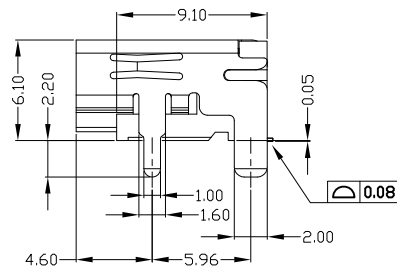
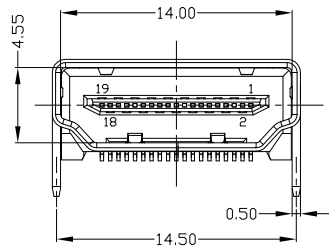
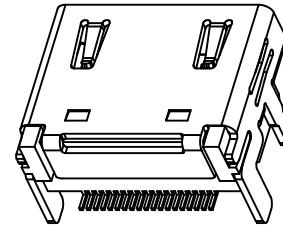
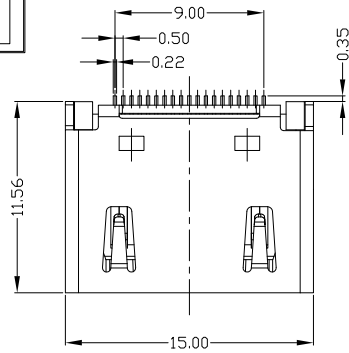

RECOMMENDED PCB LAYOUT (T=1.60mm)

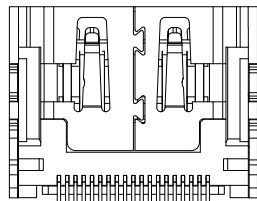

NOTES:

- ELECTRICAL:
 - VOLTAGE CURRENT RATING: 0.5AMP,30V AC;
 - INSULATION RESISTANCE: 1000MΩ MIN;
 - CONTACT RESISTANCE: 30mΩ MAX;
 - WITHSTANDING VOLTAGE: 500V AC;
 - OPERATING TEMPERATURE:-20°C TO +85°C.
- Mechanical:
 - Mating Force: 35N MAX
 - Unmating Force: 10N MIN.
- DIMENSIONS MARKED "▼" TO BE CHECKED BY Q.C & IPQC.

4.PART NO.

HMAF-191N-4BHS49-S-H

N:Ni
G:Au
1:Au 1U"
5:Au 15U"

Bill of materials:

NO	PARTS	MATERIAL	QTY	FINISHING	UNITS	mm	东莞市腾兴电子有限公司					
3	HOUSING	LCP+30%GF	1	UL94V-0	X. ±0.35	X.' ±2'	SEE NOTE	TITLE:		PART NO.:		
2	SHELL	SPCC	1	PLATED NICKEL	.X ±0.3	.X' ±1'		HDMI AF 19PIN SMT 铁壳镀镍DIP脚无凸点 L=9.10 前脚1.0宽 无面		HMAF-191N-4BHS49-S-H		
1	TERMINAL	COPPER ALLOY	19	PLATED GOLD/TIN	.XX ±0.25	.XX'		DR: gan 2017/07/2		DWG NO.:		
					.XXX ±0.15	.XXX'	SEE NOTE	CHKD: gan 2017/07/2		AII-HS49-S-H		
					THESE DRAWINGS AND SPECIFICATIONS ARE THE PROPERTY OF ACCURATE INNOTECH INC AND SHALL NOT BE REPRODUCED, COPIED OR USED IN ANY MANNER WITHOUT THE PRIOR WRITTEN CONSENT OF ACCURATE INNOTECH INC.		Q'TY	APPD:	SCALE	SHEET	REV.	CUSTOMER DRAWING
								gan 2017/07/2	1:1	1/1	B	