

REV.	ECN.	NO.	APPD.

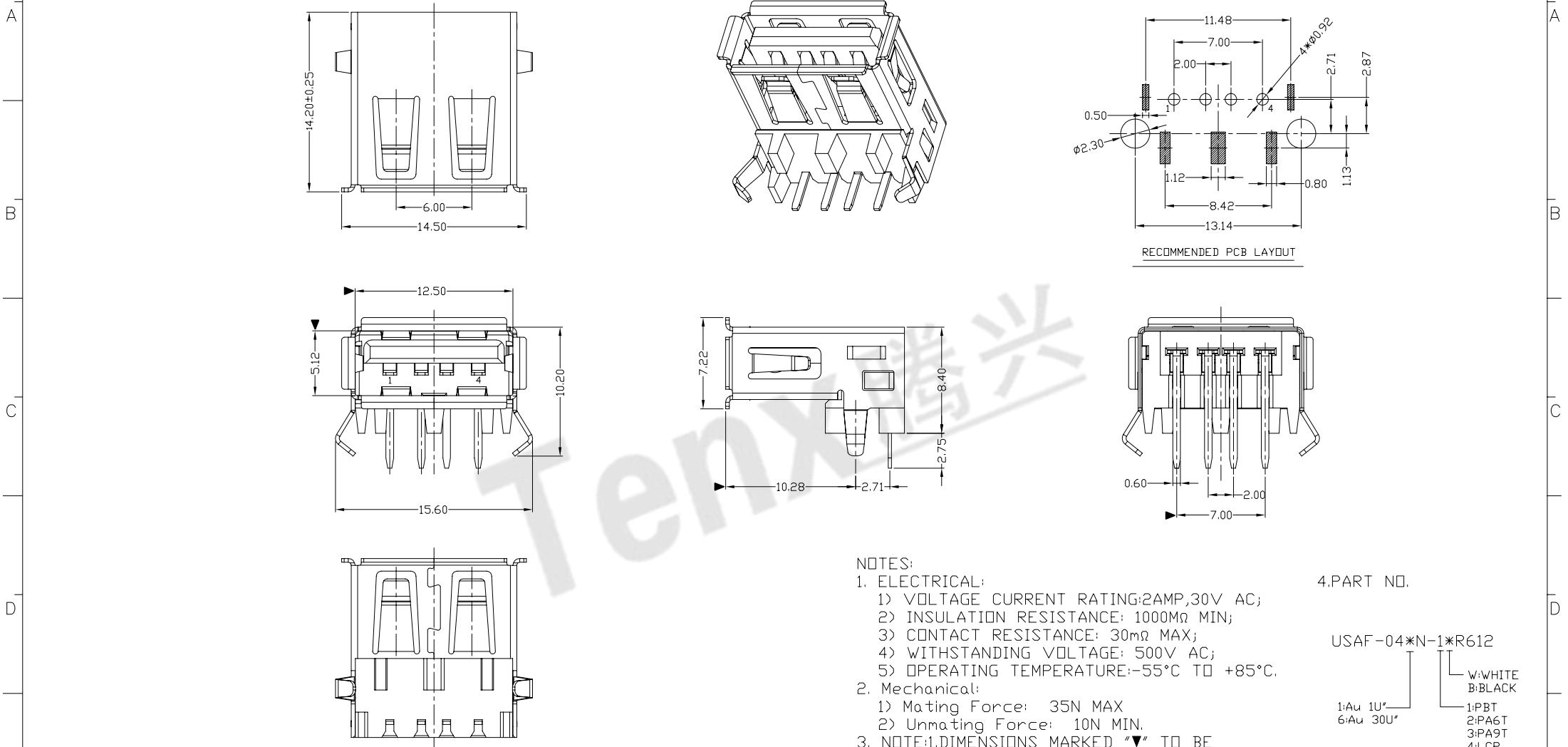

- NOTES:**
- ELECTRICAL:**
 - VOLTAGE CURRENT RATING: 2AMP, 30V AC;
 - INSULATION RESISTANCE: 1000MΩ MIN;
 - CONTACT RESISTANCE: 30mΩ MAX;
 - WITHSTANDING VOLTAGE: 500V AC;
 - OPERATING TEMPERATURE: -55°C TO +85°C.
 - Mechanical:**
 - Mating Force: 35N MAX
 - Unmating Force: 10N MIN.
 - NOTE: 1. DIMENSIONS MARKED "▼" TO BE CHECKED BY Q.C & IPQC.

4. PART NO.
USAF-04*N-1*R612
 W: WHITE
 B: BLACK
 1: Au 1U'
 6: Au 30U'
 1: PBT
 2: PA6T
 3: PA9T
 4: LCP

Bill of materials:

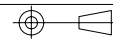
3	HOUSING	PBT	1	UL94V-0	X. ±0.35	X.' ±2'	UNITS	mm	东莞市腾兴电子有限公司 TITLE: USB A/F加高型(H8.4) PART NO.: USAF-04*N-1*R612 DR: gan 2012/6/29 DWG NO.: AII-R612 CHKD: gan 2012/6/29 APPD:
2	SHELL	COPPER ALLOY	1	PLATED NICKEL	.X ±0.3	.X' ±1'	MAT'L	SEE NOTE	
1	TERMINAL	COPPER ALLOY	4	PLATED GOLD/TIN	.XX ±0.25	.XX'	FINISH	SEE NOTE	
NO	PARTS	MATERIAL	QTY	FINISHING	.XXX ±0.15	.XXX'	Q'TY	SEE NOTE	
<small>THESE DRAWINGS AND SPECIFICATIONS ARE THE PROPERTY OF ACCURATE INNOTECH INC AND SHALL NOT BE REPRODUCED, COPIED OR USED IN ANY MANNER WITHOUT THE PRIOR WRITTEN CONSENT OF ACCURATE INNOTECH INC.</small>									SCALE: 1:1 SHEET: 1/1 REV.: B CUSTOMER DRAWING