

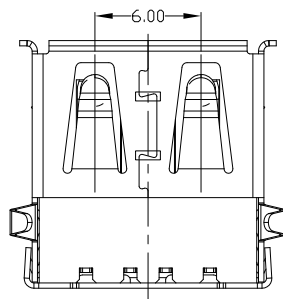

RoHS
Compliant
2002/95/EC

REV.	ECN.	NO.	APPD.

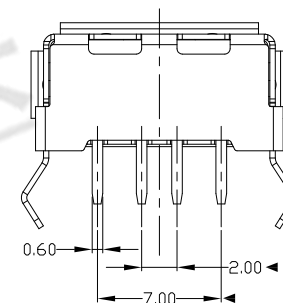
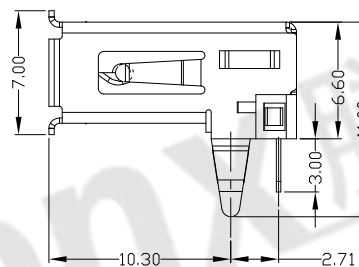
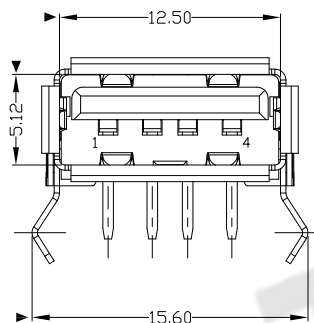
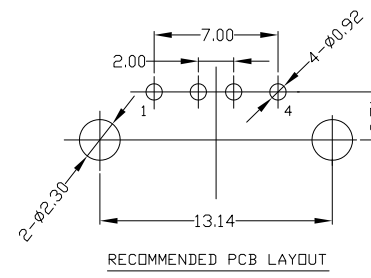
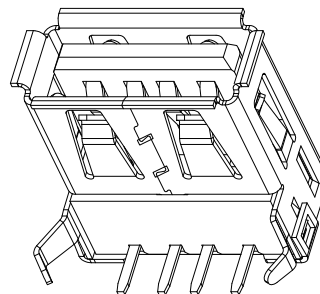
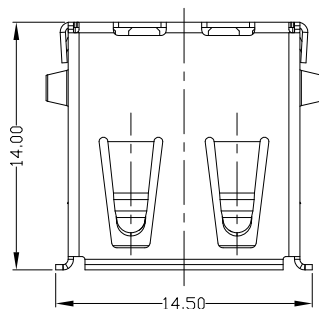

NOTES:

- ELECTRICAL:
 - VOLTAGE CURRENT RATING: 2AMP, 30V AC;
 - INSULATION RESISTANCE: 1000MΩ MIN;
 - CONTACT RESISTANCE: 30mΩ MAX;
 - WITHSTANDING VOLTAGE: 500V AC;
 - OPERATING TEMPERATURE: -55°C TO +85°C.
- Mechanical:
 - Mating Force: 35N MAX
 - Unmating Force: 10N MIN.
- NOTE: 1. DIMENSIONS MARKED "▼"
TO BE CHECKED BY Q.C & IPQC.

4. PART NO.

USAF-04*N-1*R615

1: Au 1U'
6: Au 30U'

W: WHITE
B: BLACK
1: PBT
2: PA6T
3: PA9T
4: LCP

Bill of materials:

NO	PARTS	MATERIAL	QTY	FINISHING	UNITS	mm	东莞市腾兴电子有限公司					
3	HOUSING	PBT	1	UL94V-0	X. ±0.35	X.' ±2'	SEE NOTE	TITLE: USB AF 90度DIP 一型弯脚 外扣式		PART NO.: USAF-04*N-1*R615		
2	SHELL	COPPER ALLOY	1	PLATED NICKEL	.X ±0.3	.X' ±1'		DR: gan 2012/5/29		DWG NO.: AII-R615		
1	TERMINAL	COPPER ALLOY	4	PLATED GOLD/TIN	.XXX ±0.15	.XXX'		CHKD: gan 2012/5/29		SCALE: 1:1	SHEET: 1/1	REV.: B
THESE DRAWINGS AND SPECIFICATIONS ARE THE PROPERTY OF ACCURATE INNO TECH INC AND SHALL NOT BE REPRODUCED, COPIED OR USED IN ANY MANNER WITHOUT THE PRIOR WRITTEN CONSENT OF ACCURATE INNO TECH INC.							Q'TY	APPD:				