

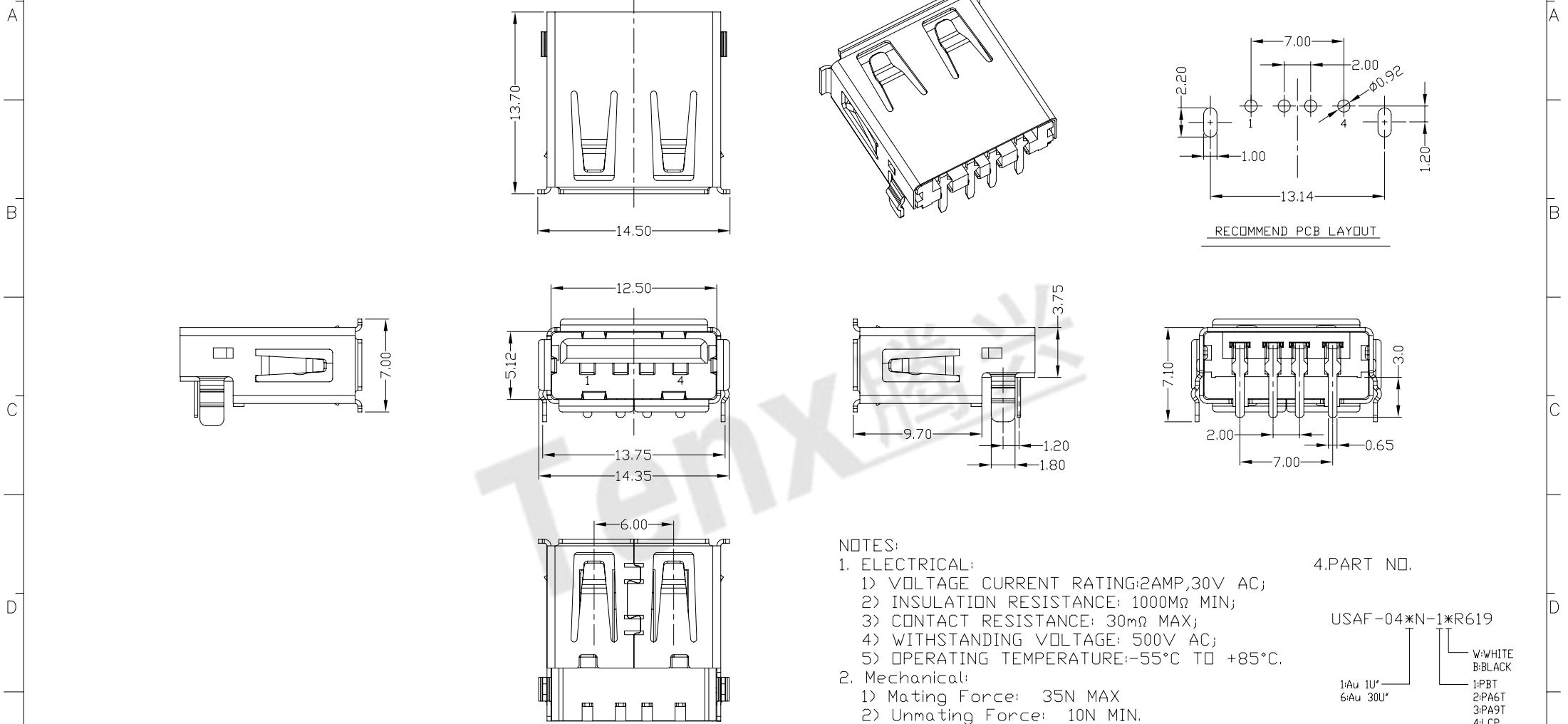

RoHS
Compliant
2002/95/EC

REV.	ECN.	NO.	APPD.



- NOTES:
- ELECTRICAL:
 - VOLTAGE CURRENT RATING: 2AMP, 30V AC;
 - INSULATION RESISTANCE: 1000M Ω MIN;
 - CONTACT RESISTANCE: 30m Ω MAX;
 - WITHSTANDING VOLTAGE: 500V AC;
 - OPERATING TEMPERATURE: -55°C TO +85°C.
 - Mechanical:
 - Mating Force: 35N MAX
 - Unmating Force: 10N MIN.
 - NOTE: 1. DIMENSIONS MARKED "▼" TO BE CHECKED BY Q.C & IPQC.

4. PART NO.
USAF-04*N-1*R619
1: Au 1U*
6: Au 30U*
W: WHITE
B: BLACK
1: PBT
2: PA6T
3: PA9T
4: LCP

Bill of materials:

3	HOUSING	PBT+30%GF	1	UL94V-0
2	SHELL	COPPER ALLOY/SPCC	1	PLATED NICKEL
1	TERMINAL	COPPER ALLOY	4	Plated Gold in Mating Area; Tin on Solder Tails
NO	PARTS	MATERIAL	QTY	FINISHING

X. ± 0.35	X.* $\pm 2^*$	UNITS	mm			
.X ± 0.3	.X* $\pm 1^*$	MAT'L	SEE NOTE			
.XXX ± 0.15	.XXX*	FINISH	SEE NOTE			
THESE DRAWINGS AND SPECIFICATIONS ARE THE PROPERTY OF ACCURATE INNTECH INC AND SHALL NOT BE REPRODUCED, COPIED OR USED IN ANY MANNER WITHOUT THE PRIOR WRITTEN CONSENT OF ACCURATE INNTECH INC.		Q'TY	SEE NOTE			
			UNITS mm			
		东莞市腾兴电子有限公司				
		TITLE:	USB AF 90度 沉板2E (13.70)长脚短端		PART NO.:	USAF-04*N-1*R619
		DR:	gan 2016/04/07		DWG NO.:	AII-R619
		CHKD:	gan 2016/04/07		SCALE	SHEET
		APPD:	1:1	1/1	REV.	CUSTOMER DRAWING
			B			