

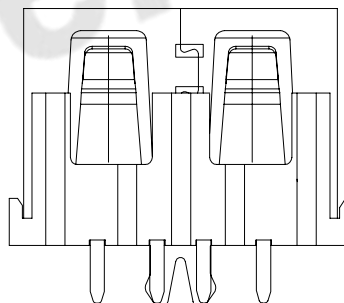

RoHS  
Compliant  
2002/95/EC

REV.	ECN. NO.	APPD.

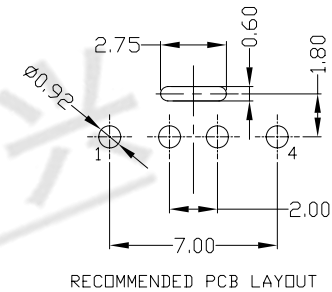
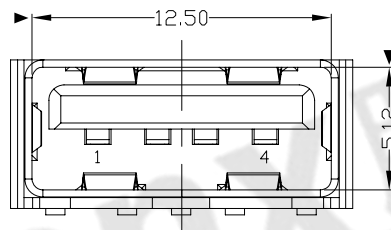
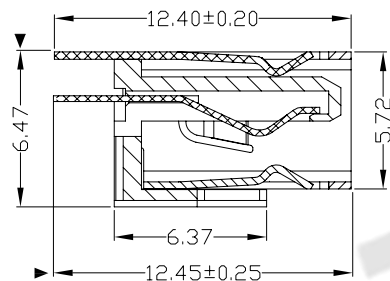
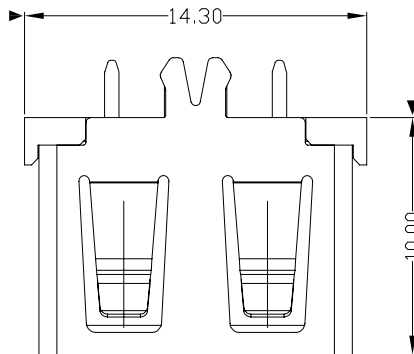

NOTES:

- ELECTRICAL:
  - VOLTAGE CURRENT RATING: 2AMP, 30V AC;
  - INSULATION RESISTANCE: 1000MΩ MIN;
  - CONTACT RESISTANCE: 30mΩ MAX;
  - WITHSTANDING VOLTAGE: 500V AC;
  - OPERATING TEMPERATURE: -55°C TO +85°C.
- Mechanical:
  - Mating Force: 35N MAX
  - Unmating Force: 10N MIN.
- NOTE: 1. DIMENSIONS MARKED "▼" TO BE CHECKED BY Q.C & IPQC.

4. PART NO.

USAF-04\*N-\*\*\*P803

1: Au 1U'  
6: Au 30U'

W: WHITE  
B: BLACK  
1: PBT  
2: PA6T  
3: PA9T  
4: LCP  
5: PA46  
6: PA66

Bill of materials:

NO	PARTS	MATERIAL	QTY	FINISHING	UNITS	mm	东莞市腾兴电子有限公司						
3	HOUSING	PBT/PA66	1	UL94V-0	X. ±0.35	X.' ±2*	MAT'L	TITLE:		PART NO.:			
2	SHELL	COPPER ALLOY	1	PLATED NICKEL	.XX ±0.25	.XX*		SEE NOTE	USB AF 180度 插板(10.0)无卷边		USAF-04*N-***P803		
1	TERMINAL	COPPER ALLOY	4	PLATED GOLD/TIN	.XXX ±0.15	.XXX*	FINISH	DR: gan 2013/03/18		DWG NO.:			
					THESE DRAWINGS AND SPECIFICATIONS ARE THE PROPERTY OF ACCURATE INNTECH INC AND SHALL NOT BE REPRODUCED, COPIED OR USED IN ANY MANNER WITHOUT THE PRIOR WRITTEN CONSENT OF ACCURATE INNTECH INC.		SEE NOTE	CHKD: gan 2013/03/18		AII-P803			
							Q'TY	APPD: gan 2013/03/18		SCALE	SHEET	REV.	CUSTOMER DRAWING
										1:1	1/1	B	