

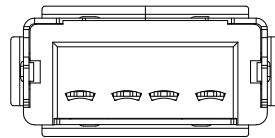

RoHS
Compliant
2002/95/EC

REV.	ECN.	NO.	APPD.

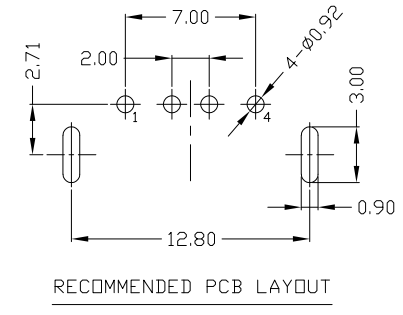
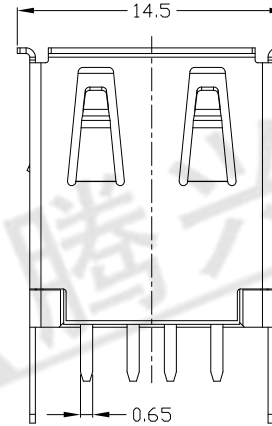
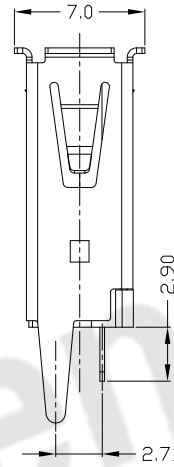
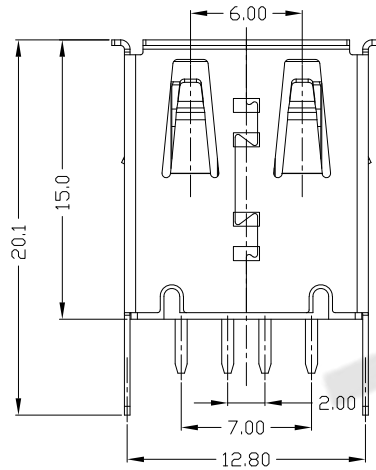
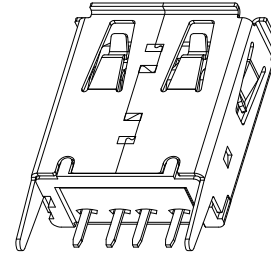
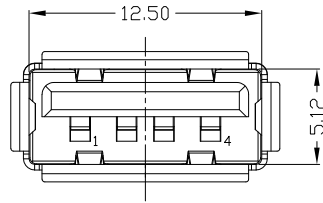

NOTES:

- ELECTRICAL:
 - VOLTAGE CURRENT RATING: 2AMP, 30V AC;
 - INSULATION RESISTANCE: 1000MΩMIN;
 - CONTACT RESISTANCE: 30mΩMAX;
 - WITHSTANDING VOLTAGE: 500V AC;
 - OPERATING TEMPERATURE: -55°C TO +85°C.
- Mechanical:
 - Mating Force: 35N MAX
 - Unmating Force: 10N MIN.
- DIMENSIONS MARKED "▼" TO BE CHECKED BY Q.C & IPQC.

4. PART NO.

USAF-04*N-1*P602

1: Au 1U*
6: Au 30U*

W: WHITE
B: BLACK
1: PBT
2: PA6T
3: PA9T
4: LCP

Bill of materials:

NO	PARTS	MATERIAL	QTY	FINISHING	UNITS	mm	东莞市腾兴电子有限公司						
4	COVER	PBT+30%GF	1	UL94V-0	X. ±0.35	X.' ±2'	MAT'L	TITLE: USB AF DIP 180° 全直脚 卷边 (15.0)		PART NO.: USAF-04*N-1*P602			
3	HOUSING	PBT+30%GF	1	UL94V-0	.X ±0.3	.X' ±1'						SEE NOTE	DR: gan 2016/9/20
2	SHELL	COPPER ALLOY/SPCC	1	PLATED NICKEL	.XX ±0.25	.XX'	FINISH	CHKD: gan 2016/9/20		SCALE	SHEET	REV.	CUSTOMER
1	TERMINAL	COPPER ALLOY	4	PLATED GOLD/TIN	.XXX ±0.15	.XXX'	SEE NOTE	APPD:		1:1	1/1	B	DRAWING
<small>THESE DRAWINGS AND SPECIFICATIONS ARE THE PROPERTY OF ACCURATE INNOVTECH INC. AND SHALL NOT BE REPRODUCED, COPIED OR USED IN ANY MANNER WITHOUT THE PRIOR WRITTEN CONSENT OF ACCURATE INNOVTECH INC.</small>					Q'TY								