

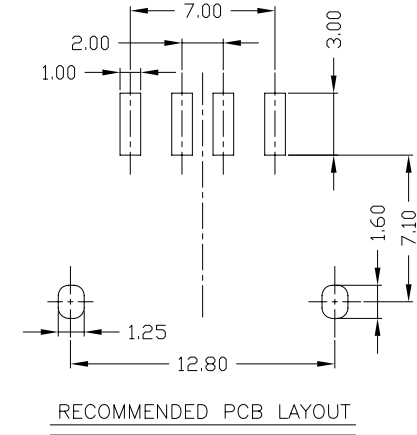

RoHS
Compliant
2002/95/EC

REV	LTR	DESCRIPTION	DATE	REVISER	APPD

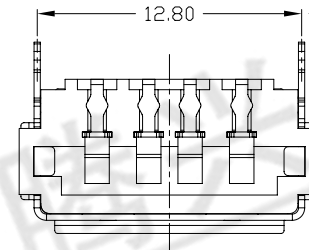
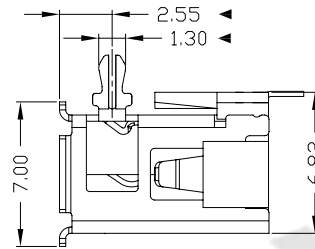
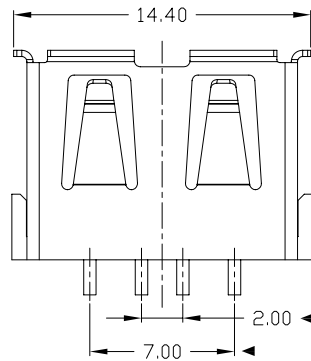
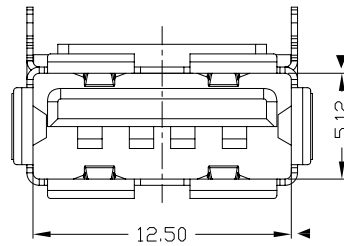
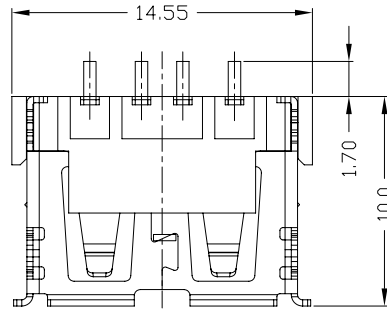

NOTES:

- ELECTRICAL:
 - VOLTAGE CURRENT RATING: 2AMP, 30V AC;
 - INSULATION RESISTANCE: 1000MΩ MIN;
 - CONTACT RESISTANCE: 30mΩ MAX;
 - WITHSTANDING VOLTAGE: 500V AC;
 - OPERATING TEMPERATURE: -55°C TO +85°C.
- Mechanical:
 - Mating Force: 35N MAX
 - Unmating Force: 10N MIN.
- NOTE: 1. DIMENSIONS MARKED "▼" TO BE CHECKED BY Q.C & IPQC.

4. PART NO.

USAF-04*N-5*VU01

1:Au 1U"
6:Au 30U"

W: WHITE
B: BLACK

1: PBT
2: PA6T
3: PA9T
4: LCP
5: PA46

Bill of materials:

NO	PARTS	MATERIAL	QTY	FINISHING
3	HOUSING	PA46/PBT+30%GF	1	UL94V-0
2	SHELL	COPPER ALLOY	1	PLATED NICKEL
1	TERMINAL	COPPER ALLOY	4	PLATED GOLD/TIN

UNITS	东莞市腾兴电子有限公司			
mm	TITLE: USB AF 90度 超短反向前两脚无卷边 SMT(贴板脚1.7)		PART NO.: USAF-04*N-5*VU01	
MAT'L	DR: gan 2015/07/14		DWG NO.: AII-VU01	
SEE NOTE	CHKD: gan 2015/07/14		SCALE	SHEET
FINISH	APPD:		1:1	1/1
SEE NOTE	Q'TY		REV.	CUSTOMER
SEE NOTE	DRAWING SYMBOL		B	DRAWING

THESE DRAWINGS AND SPECIFICATIONS ARE THE PROPERTY OF ACCURATE INNOVATECH INC AND SHALL NOT BE REPRODUCED, COPIED OR USED IN ANY MANNER WITHOUT THE PRIOR WRITTEN CONSENT OF ACCURATE INNOVATECH INC.