

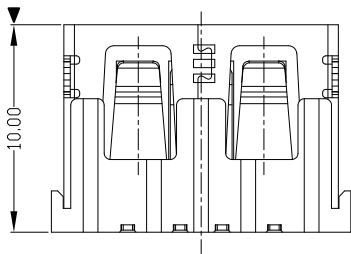

RoHS
Compliant
2002/95/EC

REV	LTR	DESCRIPTION	DATE	REVISER	APPD

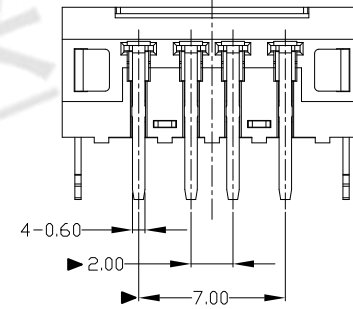
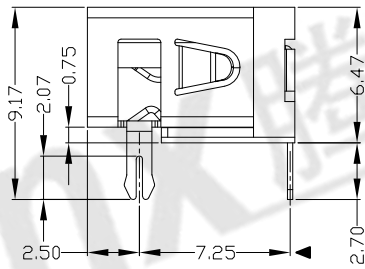
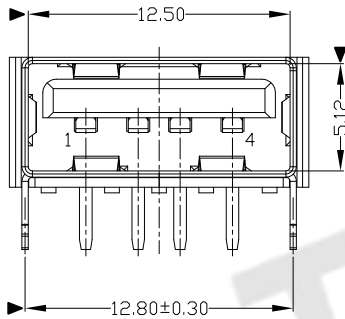
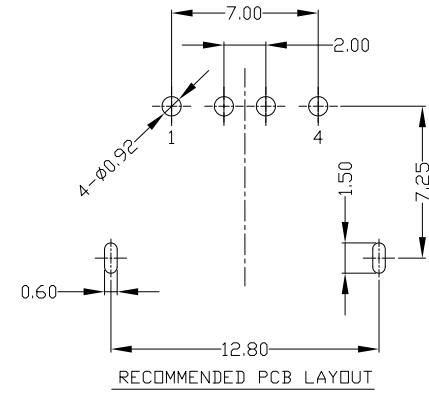
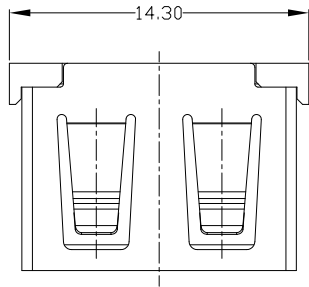

NOTES:

- ELECTRICAL:
 - VOLTAGE CURRENT RATING: 2AMP, 30V AC;
 - INSULATION RESISTANCE: 1000MΩ, MIN;
 - CONTACT RESISTANCE: 30mΩ MAX;
 - WITHSTANDING VOLTAGE: 500V AC;
 - OPERATING TEMPERATURE: -55°C TO +85°C.
- Mechanical:
 - Mating Force: 35N MAX
 - Unmating Force: 10N MIN.
- NOTE: 1. DIMENSIONS MARKED " " TO BE CHECKED BY Q.C & IPQC.

4. PART NO.

USAF-04*N-1*R613
 1: Au 1U*
 6: Au 30U*
 W: WHITE
 B: BLACK
 1: PBT
 2: PA6T
 3: PA9T
 4: LCP

Bill of materials:

NO	PARTS	MATERIAL	QTY	FINISHING	UNITS	mm	东莞市腾兴电子有限公司					
3	HOUSING	PBT	1	UL94V-0	X. ±0.35	X.' ±2'	MAT'L	TITLE: USB AF DIP 90° (10.0)无卷边		PART NO.: USAF-04*N-1*R613		
2	SHELL	COPPER ALLOY	1	PLATED NICKEL	.X ±0.30	.X' ±1'						SEE NOTE
1	TERMINAL	COPPER ALLOY	4	PLATED GOLD/TIN	.XX ±0.25	.XX'	FINISH	CHKD: gan 2013/4/12	SCALE	SHEET	REV.	CUSTOMER DRAWING
					.XXX ±0.15	.XXX'	SEE NOTE	APPD:	1:1	1/1	B	
					THESE DRAWINGS AND SPECIFICATIONS ARE THE PROPERTY OF ACCURATE INNOTECH INC AND SHALL NOT BE REPRDUCED, COPIED OR USED IN ANY MANNER WITHOUT THE PRIOR WRITTEN CONSENT OF ACCURATE INNOTECH INC.		Q'TY					