

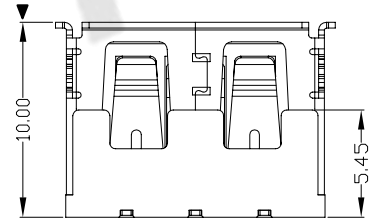

RoHS
Compliant
2002/95/EC

REV	LTR	DESCRIPTION	DATE	REVISER	APPD

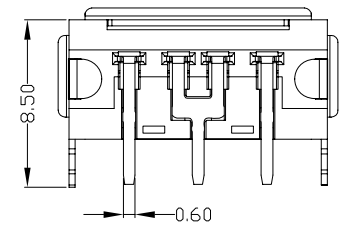
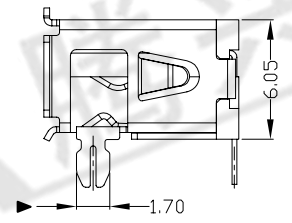
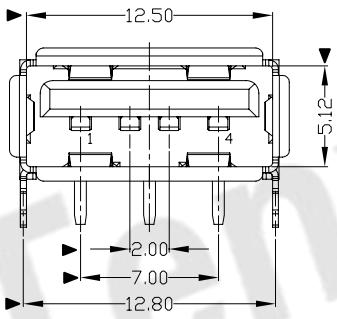
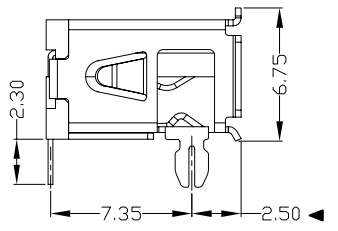
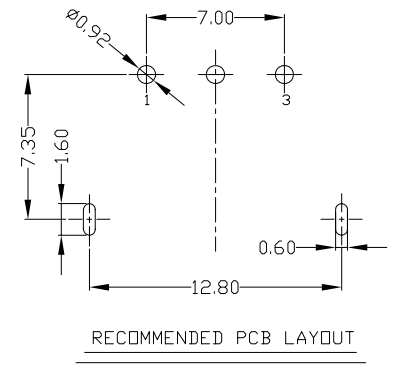
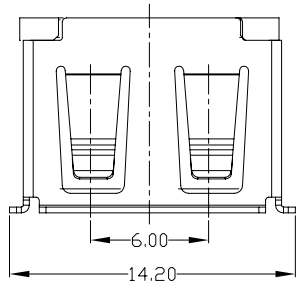

- NOTES:
- ELECTRICAL:
 - VOLTAGE CURRENT RATING: 2AMP, 30V AC;
 - INSULATION RESISTANCE: 1000MΩ, MIN;
 - CONTACT RESISTANCE: 30mΩ MAX;
 - WITHSTANDING VOLTAGE: 500V AC;
 - OPERATING TEMPERATURE: -55°C TO +85°C.
 - Mechanical:
 - Mating Force: 35N MAX
 - Unmating Force: 10N MIN.
 - NOTE: 1. DIMENSIONS MARKED "▼" TO BE CHECKED BY Q.C & IPQC.

4. PART NO.
USAF-04*N-1*R622

1: Au 1U*
6: Au 30U*

W: WHITE
B: BLACK
1: PBT
2: PA6T
3: PA9T
4: LCP

Bill of materials:

NO	PARTS	MATERIAL	QTY	FINISHING	UNITS	mm	东莞市腾兴电子有限公司						
3	HOUSING	PBT+30%GF	1	UL94V-0	X. ±0.35	X.* ±2'	MAT'L	TITLE:		PART NO.:			
2	SHELL	COPPER ALLOY	1	PLATED NICKEL	.X ±0.30	.X* ±1'	SEE NOTE	USB AF DIP 90度 10.0二三短路3P		USAF-04*N-1*R622			
1	TERMINAL	COPPER ALLOY	4	PLATED GOLD/TIN	.XX ±0.25	.XX*	FINISH	DR: gan 2013/5/9		DWG NO.:			
					.XXX ±0.15	.XXX*	SEE NOTE	CHKD: gan 2013/5/9		AII-R622			
					THESE DRAWINGS AND SPECIFICATIONS ARE THE PROPERTY OF ACCURATE INNOTECH INC AND SHALL NOT BE REPRODUCED, COPIED OR USED IN ANY MANNER WITHOUT THE PRIOR WRITTEN CONSENT OF ACCURATE INNOTECH INC.		Q'TY	APPD: gan 2013/5/9		SCALE	SHEET	REV.	CUSTOMER DRAWING
								1:1	1/1	B			