

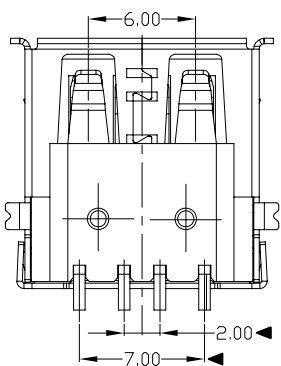

RoHS
Compliant
2002/95/EC

REV.	ECN.	NO.	APPD.

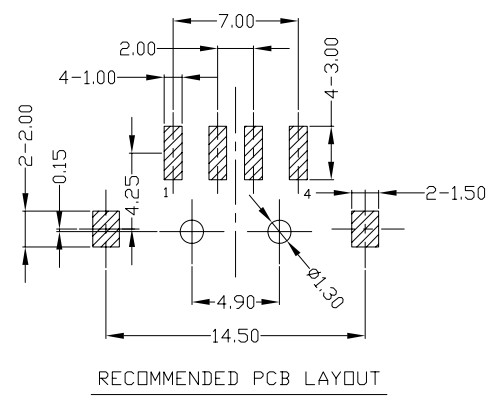
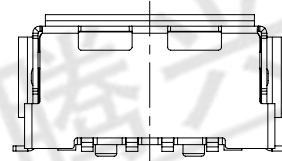
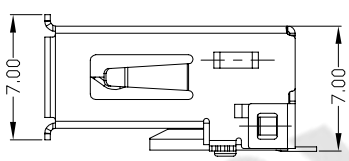
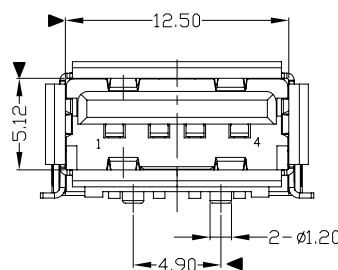
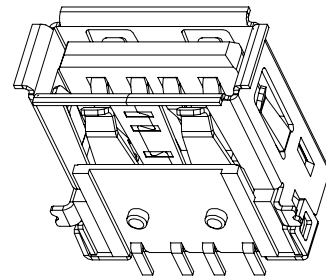
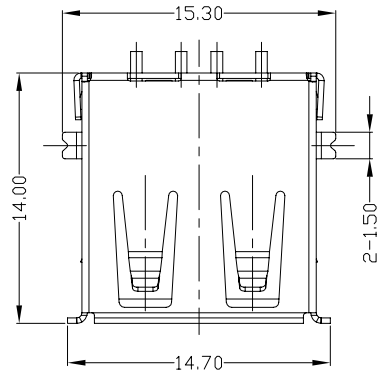

NOTES:

- ELECTRICAL:
 - VOLTAGE CURRENT RATING: 2AMP,30V AC;
 - INSULATION RESISTANCE: 1000MΩ MIN;
 - CONTACT RESISTANCE: 30mΩ MAX;
 - WITHSTANDING VOLTAGE: 500V AC;
 - OPERATING TEMPERATURE:-55°C TO +85°C.
- Mechanical:
 - Mating Force: 35N MAX
 - Unmating Force: 10N MIN.
- DIMENSIONS MARKED "▼" TO BE CHECKED BY Q.C & IPQC.

4.PART NO

USAF-04*N-4*V62

W:WHITE
B:BLACK

1:Au 1U"
6:Au 30U"

1:PBT
2:PA6T
3:PA9T
4:LCP

Bill of materials:

3	HOUSING	LCP	1	UL94V-0	X. ±0.35	X.' ±2°	UNITS	mm	东莞市腾兴电子有限公司	
2	SHELL	COPPER ALLOY	1	PLATED NICKEL	.XX ±0.25	.XX°	MAT'L	SEE NOTE		
1	TERMINAL	COPPER ALLOY	4	PLATED GOLD/TIN	.XXX ±0.15	.XXX°	FINISH	SEE NOTE		
NO	PARTS	MATERIAL	QTY	FINISHING	<small>THESE DRAWINGS AND SPECIFICATIONS ARE THE PROPERTY OF ACCURATE INNTECH INC AND SHALL NOT BE REPRODUCED, COPIED OR USED IN ANY MANNER WITHOUT THE PRIOR WRITTEN CONSENT OF ACCURATE INNTECH INC.</small>		Q'TY	SEE NOTE		
									TITLE: USB A/F SMT TYPE全贴 鱼叉脚 PART NO.: USAF-04*N-4*V62 DR: gan 2012/6/30 DWG NO.: AII-V62 CHKD: gan 2012/6/30 APPD:	SCALE: 1:1 SHEET: 1/1 REV.: B CUSTOMER DRAWING