

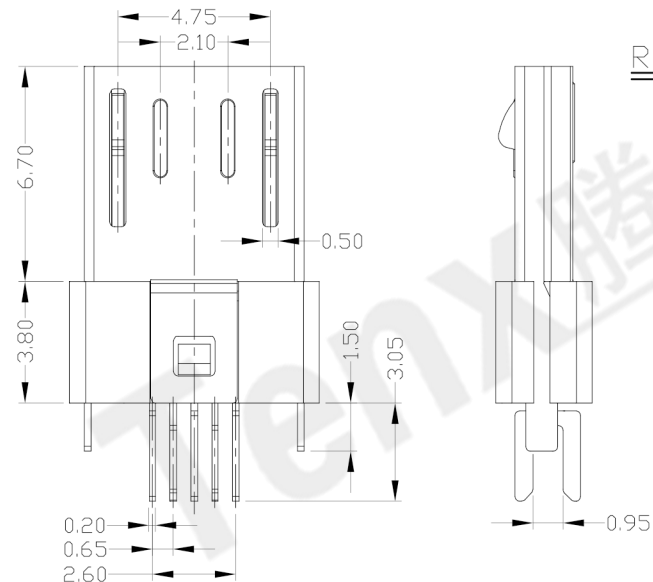

RoHS
Compliant
2002/95/EC

REV.	ECN. NO.	APPD.

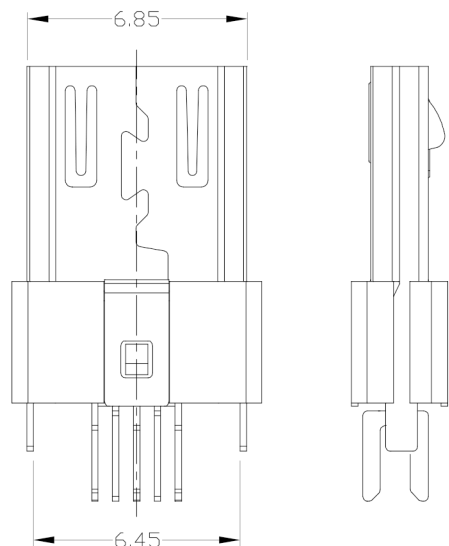
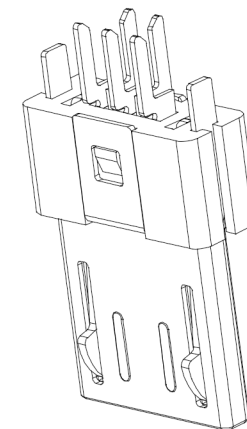
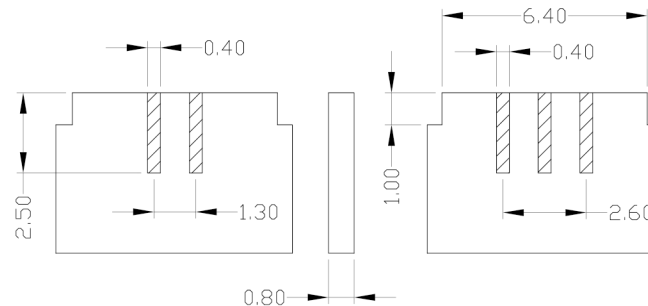
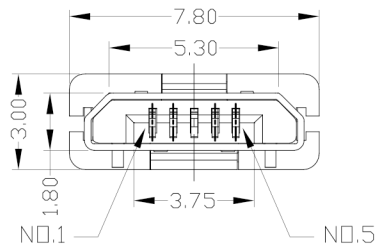

RECOMMENDED P.C.B. LAYOUT

NOTES:

- ELECTRICAL:
 - VOLTAGE CURRENT RATING: 1.5AMP, 250V AC;
 - INSULATION RESISTANCE: 100MΩ MIN;
 - CONTACT RESISTANCE: 30mΩ MAX;
 - WITHSTANDING VOLTAGE: 30V AC;
 - OPERATING TEMPERATURE: -20°C TO +85°C.
- Mechanical:
 - Mating Force: 35N MAX
 - Unmating Force: 8N MIN.
- DIMENSIONS MARKED "▼" TO BE CHECKED BY Q.C & IPQC.
- PART NO.

MUYM-05*N-5BSH12

- 1: Au 1U'
- 6: Au 30U'
- W: WHITE
- B: BLACK
- 1: PBT
- 2: PA6T
- 3: PA9T
- 4: LCP
- 5: PA46

Bill of materials:

NO	PARTS	MATERIAL	QTY	FINISHING
4	HOOK	STAINLESS STEEL	1	
3	HOUSING	PA46	1	
2	SHELL	STAINLESS STEEL	1	PLATED NICKEL
1	TERMINAL	COPPER ALLOY	5	PLATED GOLD/TIN

X. ±0.3	X.' ±2'	UNITS	mm
.X ±0.2	.X' ±1'	MAT'L	
.XX ±0.15	.XX'	SEE NOTE	
.XXX ±0.10	.XXX'	FINISH	
		SEE NOTE	
		Q'TY	

东莞市腾兴电子有限公司

TITLE: MICRO USB 5P MALE 夹板式 两隻接地膠		PART NO.: MUYM-05*N-5BSH12	
DR: Ricky 2017/11/27		DWG NO.: AII-SH12	
CHKD: Ricky 2017/11/27		SCALE	SHEET
APPD:		1:1	1/1
		REV.	CUSTOMER DRAWING
		B	

THESE DRAWINGS AND SPECIFICATIONS ARE THE PROPERTY OF ACCURATE INNOVATECH INC AND SHALL NOT BE REPRODUCED, COPIED OR USED IN ANY MANNER WITHOUT THE PRIOR WRITTEN CONSENT OF ACCURATE INNOVATECH INC.