

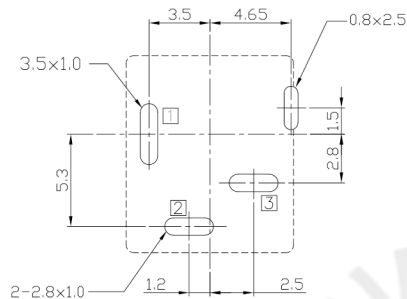

RoHS Compliant
2002/95/EC

REV.	ECN.	NO.	APPD.

DIMENSIONS

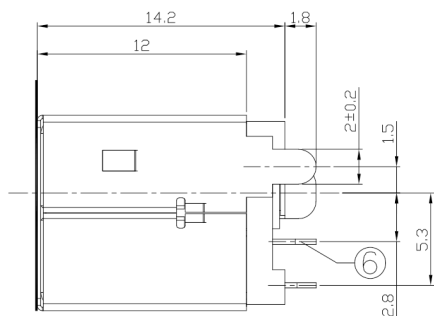
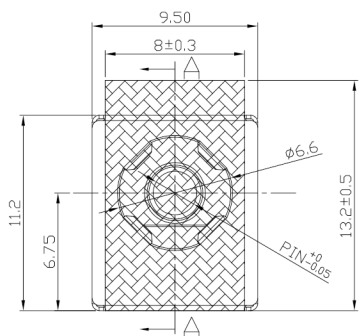

RECOMMENDED P.C.B. LAYOUT
UNSPECIFIED TOLERANCE:±0.05
(TOP VIEW)

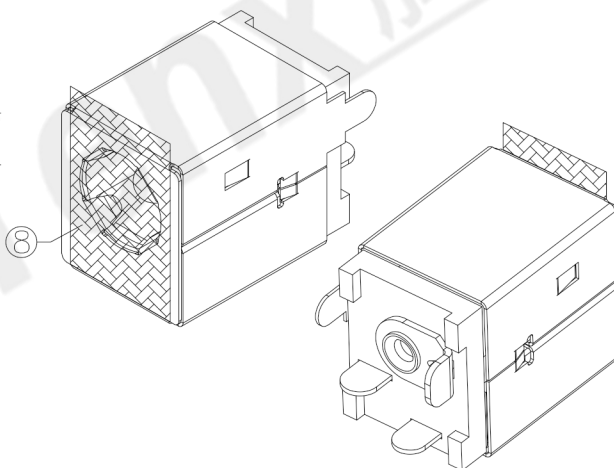
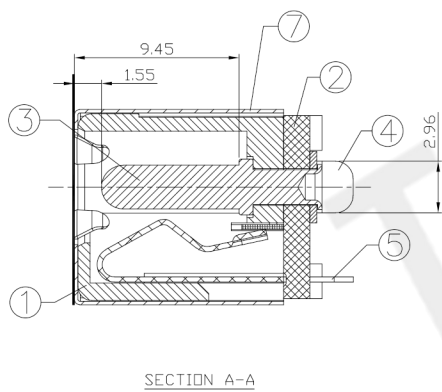
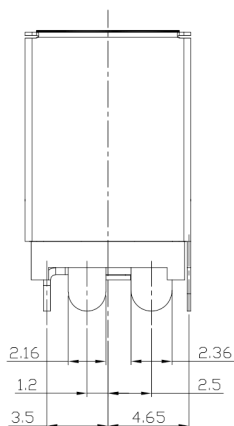

MODEL CODE:

DCB0-0012G- A □ 9T BK S 0 1
(1) (2) (3)(4) (5) (6) (7)(8) (9)
(1):Series type:DIP DC POWER JACK.
(2):Series No.
(3):Schematic option: A
(4):Center pin diameter:
G=φ1.65 , H=φ2.0 , J=φ2.5
(5):Material of housing:
9T=PA9T (Default)
(6):Housing color:
BK=Black
(7):Terminal plating
S=Silver(Ag)
(8):Special option:
0=No special option
(9):Packing mode:
1=Reel packing

Specification:

- Rating :DC 20V 7A.
- Contact resistance :≤30mΩ
After test:≤50mΩ
- Insulation resistance : ≥100MΩ (500VDC).
After test:≥50MΩ
- Withstanding voltage: 500VAC .
- Insertion and extraction force: 3N~30N.
- Life test: 5000cycles min.
- Operation temperature range:-20℃~70℃.
- Preservative temperature range:-40℃~85℃.

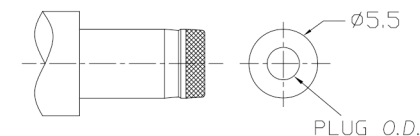
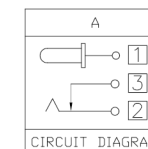

DC MATE PLUG

Model No.	G	H	J
CENTER PIN	φ1.65	φ2.0	φ2.5
PLUG O.D.	φ1.70 ^{+0.10} _{-0.00}	φ2.05 ^{+0.10} _{-0.00}	φ2.55 ^{+0.10} _{-0.00}

○: ITEM NO. □: TERMINAL NO.

NO.	PARTS	MATERIAL	Q'TY	FINISHING
⑧	Mylar	Polyimide	1	Yellow
⑦	Shell	Stainless stell t=0.2	1	Nickel plating
⑥	Shunt terminal ③	Brass t=0.3	1	Silver plating
⑤	Tip spring ②	Phosphor bronze t=0.3	1	Silver plating
④	Center pin terminal ①	Brass t=0.4	1	Silver plating
③	Center pin ①	Brass	1	Nickel plating
②	Cover	PA9T,UL94V-0	1	Black
①	Housing	PA9T,UL94V-0	1	Black

THESE DRAWINGS AND SPECIFICATIONS ARE THE PROPERTY OF ACCURATE INNOVATECH INC AND SHALL NOT BE REPRODUCED, COPIED OR USED IN ANY MANNER WITHOUT THE PRIOR WRITTEN CONSENT OF ACCURATE INNOVATECH INC.

TOLERANCE	ANGLES	UNITS	mm
±0.3	±2°	MAT'L	SEE NOTE
		FINISH	SEE NOTE
		Q'TY	SEE NOTE

东莞市腾兴电子有限公司

TITLE:	DIP DC POWER JACK	PART NO.:	DCB0-0012G
DR:	Ricky 2019/03/07	DWG NO.:	AB0-0012G
CHKD:	Ricky 2019/03/07	SCALE	SHEET
APPD:		1:1	1/1
		REV.	A
		CUSTOMER DRAWING	