

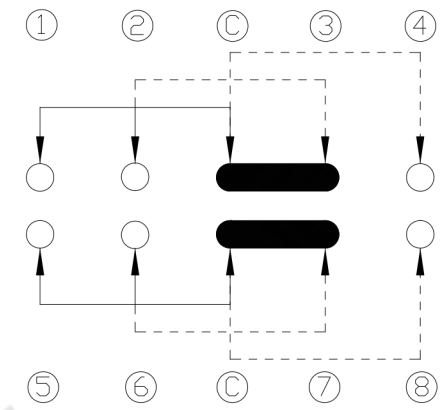

RoHS Compliant  
2002/95/EC

REV.	ECN.	NO.	APPD.

**DIMENSIONS**

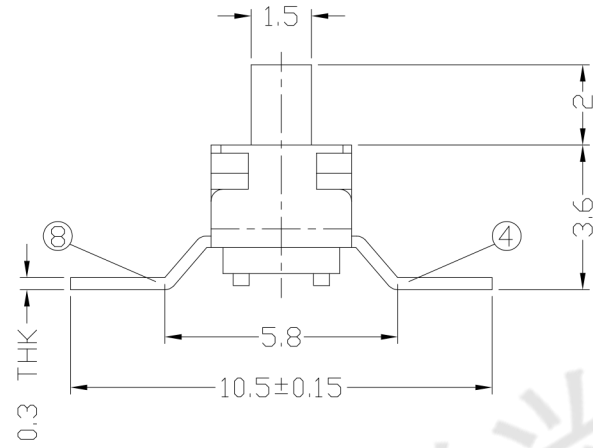
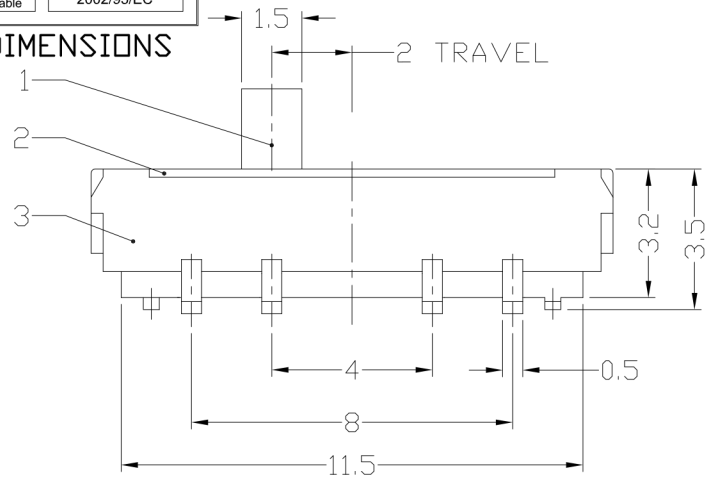

**MODEL CODE**  
AS-2336SPL - [B]

Knob Color  
B | Black

CIRCUIT DIAGRAM

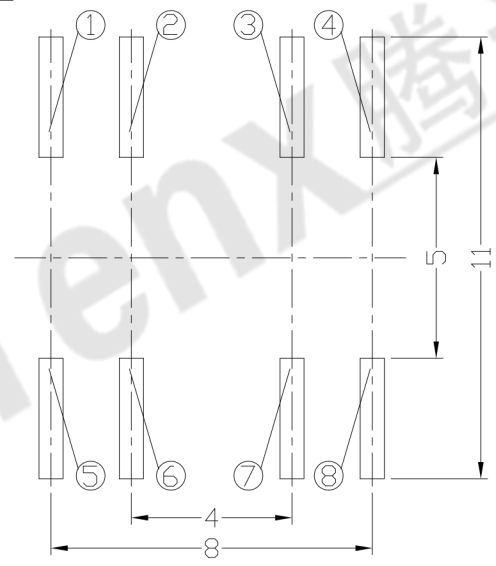
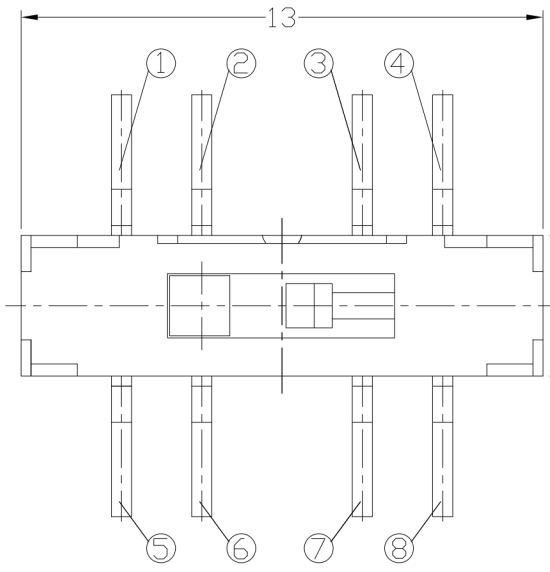

P.C.B LAYOUT  
TOP VIEW

**ELECTRO-MECHANICAL CHARACTERISTICS**  
Refer to additional specifications

RATING	DC6V 0.3A
CIRCUIT	2P3T
CONTACT RESISTANCE	70mΩ MAX.
TRAVEL	2mm
OPERATING FORCE	250±100gf
OPERATING LIFE(cycles)	10,000

NO.	PARTS	MATERIAL	Q'TY	FINISHING
8				
7				
6				
5				
4	CONTACT	PBS WIRE	2	NATURAL
3	CASE	PA6T/BRASS STRIP	1	BLACK/Ag PLATED
2	COVER	SUS	1	NATURAL
1	KNOB	PA6T	1	BLACK

WITHIN 1.5mm:±0.1mm	UNITS mm
OVER 1.5mm:±0.2mm	MAT'L
	SEE NOTE
	FINISH
	SEE NOTE
	Q'TY

**东莞市腾兴电子有限公司**

TITLE: MINI SLIDE SWITCH / VERTICAL	PART NO.: AS-2336SPL SERIES
DR: Ricky 2015/04/15	DWG NO.: ADL-2336SPL
CHKD: Ricky 2015/04/15	SCALE SHEET REV. CUSTOMER 5:1 1/1 A DRAWING
APPD:	

THESE DRAWINGS AND SPECIFICATIONS ARE THE PROPERTY OF ACCURATE INNO TECH INC AND SHALL NOT BE REPRODUCED, COPIED OR USED IN ANY MANNER WITHOUT THE PRIOR WRITTEN CONSENT OF ACCURATE INNO TECH INC.