

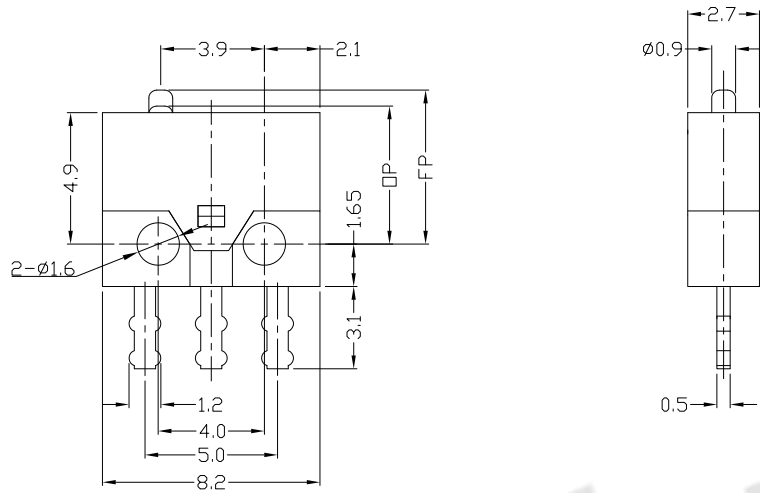

RoHS  
Compliant  
2002/95/EC

REV.	ECN.	NO.	APPD.

## DIMENSIONS



## 1.Functional spec

1.1 Rated Voltage	DC 6V
1.2 Rated Current	0.3A
1.3 Contact Resistance	≤50mΩ(Initial value)
1.4 Operating Force	90±30gf
1.5 Bounce Time	
1.6 Free Position	5.2±0.2mm
1.7 Operating Position	5.0±0.2mm
1.8 Position Travel	
1.9 Return Force	

## 2.Reliable Rating

2.1 Mechanical Life	100,000 CYCLES
2.2 Electrical Life	50,000 CYCLES
2.3 Insulation Resistance	≥100MΩ DC250V
2.4 Withstand Voltage	AC250V 1 minute
2.5 Soldering Technic	Hand/Wave soldering
2.6 Operating Temper	-25°C ~ +85°C
2.7 Ambient Humidity Used	<85%RH

## MODEL CODE

DS037-00X-XX

1 2 3 4

- 1.Series : DS037
- 2.Actuator Button : 00=Non-lever 01-99=Lever
- 3.Termination : see chart(P/C/D/C1/D1)
- 4.Operating Force : see chart

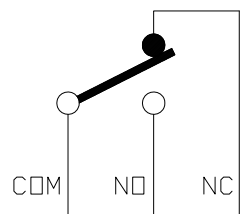

## CIRCUIT DIAGRAM

Tolerance:±0.2	UNITS	mm			
	MAT'L	SEE NOTE			
FINISH	SEE NOTE		TITLE:		PART NO.:
	SEE NOTE		Miniature MICRO SWITCH DS037 SERIES		DS037-00P-90
Q'TY	SEE NOTE		DR: <i>Ricky</i> 2017/7/19		DWG NO.:
	SEE NOTE		CHKD: <i>Ricky</i> 2017/7/19		ATD-00X-90
THESE DRAWINGS AND SPECIFICATIONS ARE THE PROPERTY OF ACCURATE INNOTECH INC AND SHALL NOT BE REPRODUCED, COPIED OR USED IN ANY MANNER WITHOUT THE PRIOR WRITTEN CONSENT OF ACCURATE INNOTECH INC.			APPD:	SCALE	SHEET
				1:1	1/2
				REV.	CUSTOMER DRAWING
				A	

东莞市腾兴电子有限公司

DR: *Ricky* 2017/7/19

CHKD: *Ricky* 2017/7/19

PART NO.: DS037-00P-90

DWG NO.: ATD-00X-90

SCALE: 1:1 SHEET: 1/2 REV.: A CUSTOMER DRAWING



RoHS  
Compliant  
2002/95/EC

REV.	ECN. NO.	APPD.

### Terminal Type

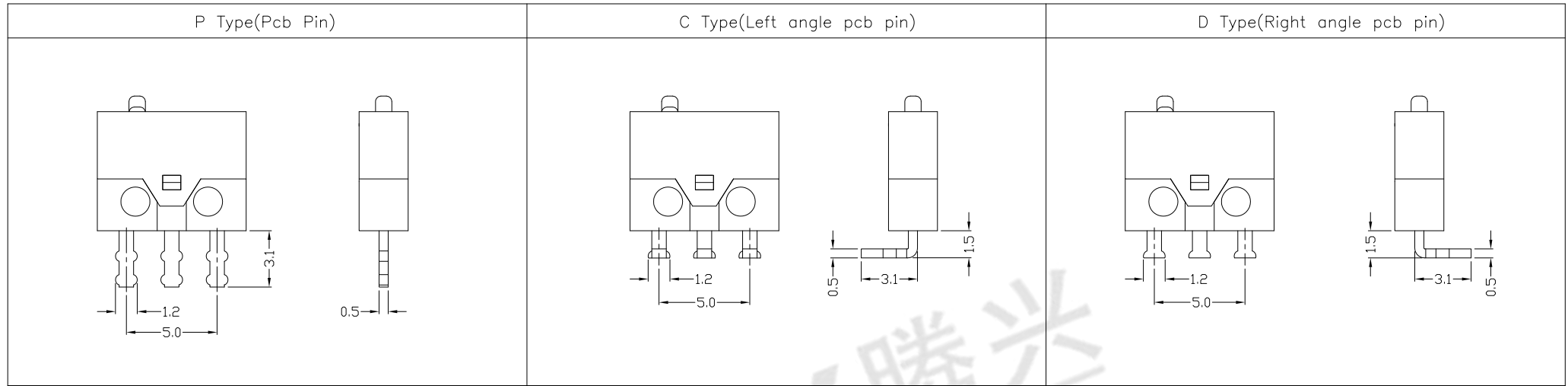

### Structure chart

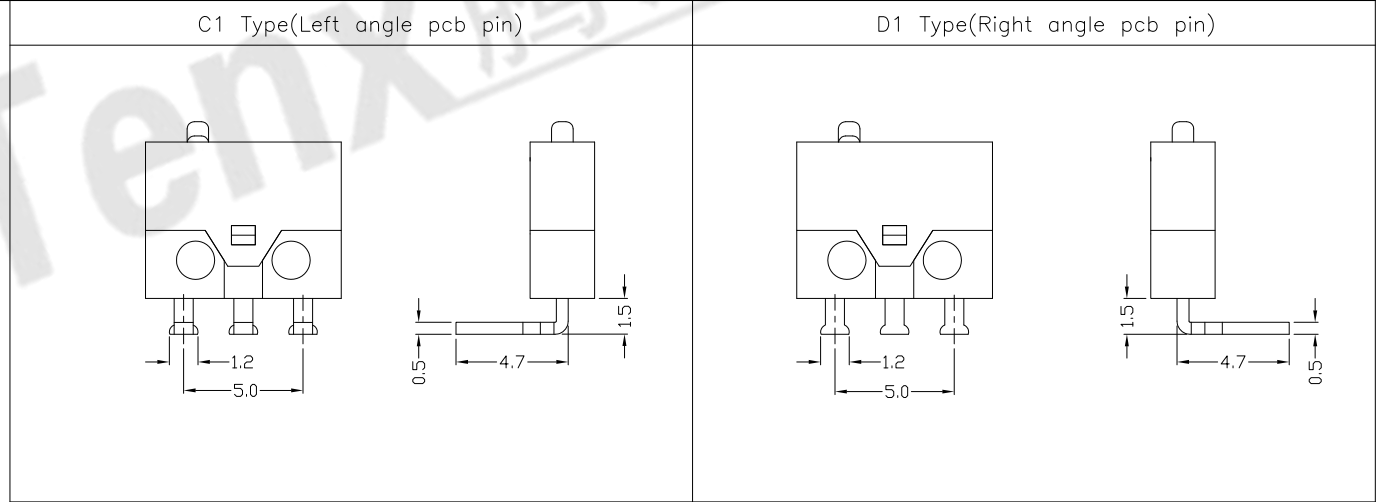
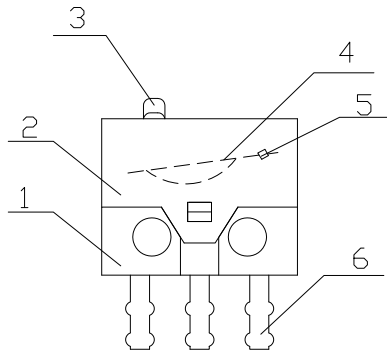

### Material list

8					
7					
6	Terminal	C2680	2		
5	Contact	Silver alloy	1		
4	Spring Plate	C1720	1		
3	Button	Nylon	1		
2	Case	Nylon	1		
1	Base	Nylon	1		
NO.	PARTS	MATERIAL	Q'TY	FINISHING	

Tolerance: ±0.2

UNITS mm

MAT'L

SEE NOTE

FINISH

SEE NOTE

Q'TY

THESE DRAWINGS AND SPECIFICATIONS ARE THE PROPERTY OF ACCURATE INNOTECH INC AND SHALL NOT BE REPRODUCED, COPIED OR USED IN ANY MANNER WITHOUT THE PRIOR WRITTEN CONSENT OF ACCURATE INNOTECH INC.

**东莞市腾兴电子有限公司**

TITLE: Miniature MICRO SWITCH DS037 SERIES

PART NO.: DS037-00X-90

DR: Ricky 2017/7/19

DWG NO.: ATD-00X-90

CHKD: Ricky 2017/7/19

APPD:

SCALE	SHEET	REV.	CUSTOMER DRAWING
1:1	2/2	A	