

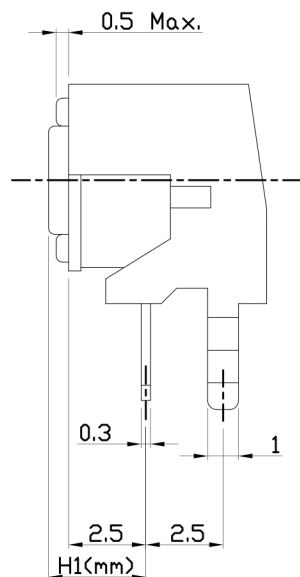

RoHS  
Compliant  
2002/95/EC

REV.	ECN.	NO.	APPD.

### DIMENSIONS

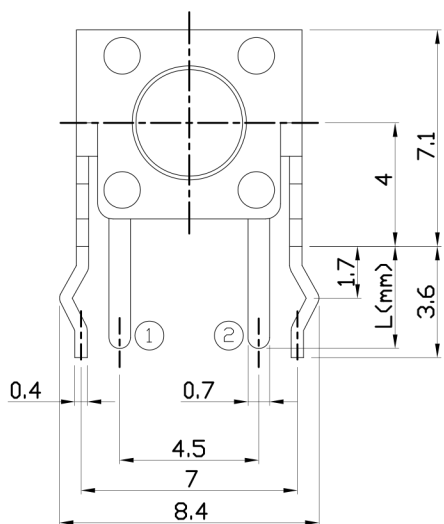

### CIRCUIT DIAGRAM



### PRODUCT IMAGE

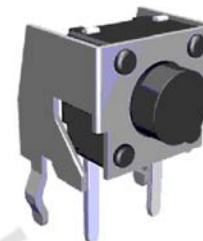

### MODEL CODE Knob/Terminal Options

AT-1102N-

	H1	H2	φA	L
-	3.15	4.3	3.5	3.5
AS	3.35	4.5	3.5	
A	3.85	5.0	3.5	
AL	4.35	5.5	3.4	
Q	4.85	6.0	3.4	
QL	5.35	6.5	3.4	
B	5.85	7.0	3.4	
E	6.15	7.3	3.4	
EL	6.35	7.5	3.4	
C	6.85	8.0	3.4	
CL	7.35	8.5	3.4	
DS	7.85	9.0	3.4	
D	8.35	9.5	3.4	
DL	8.85	10.0	3.0	
KS	9.35	10.5	3.0	
K	9.85	11.0	3.0	
KL	10.35	11.5	3.0	
FS	10.85	12.0	3.0	
F	11.35	12.5	3.0	
FL	11.85	13.0	3.0	
G	12.35	13.5	3.0	
□	12.85	14.0	3.0	
X	13.35	14.5	3.0	
Y	13.85	15.0	3.0	
Z	14.85	16.0	3.0	
J	15.15	16.3	3.0	
I	15.85	17.0	3.0	
T	□2.4X2.4			
TA	□2.8X2.8			

### P.C.B MOUNTING PATTERN DIMENSION

The following soldering patterns are recommended for reflow soldering

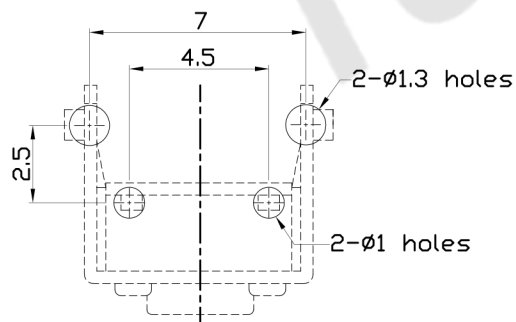
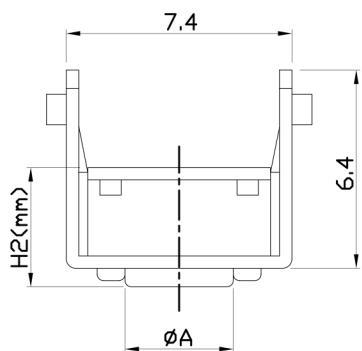

### ELECTRO-MECHANICAL CHARACTERISTICS

Refer to additional specifications

Rating	DC 12V 50mA	
Contact Resistance	100mΩ Max.	
Travel	0.25 ± 0.1mm	
Operating Force	160±30gf	250±50gf
Operating Life(cycles)	100,000	Phosphor Bronze
	200,000	Stainless Steel

东莞市腾兴电子有限公司

.X ±0.3	X. ±2'	UNITS mm
		MAT'L
		SEE NOTE
		FINISH
		SEE NOTE
		Q'TY

THESE DRAWINGS AND SPECIFICATIONS ARE THE PROPERTY OF ACCURATE INNOVATION INC AND SHALL NOT BE REPRODUCED, COPIED OR USED IN ANY MANNER WITHOUT THE PRIOR WRITTEN CONSENT OF ACCURATE INNOVATION INC.

TACT SWITCH		PART NO.: AT-1102N SERIES	
DR: Ricky 2014/03/26		DWG NO.: ASI-1102N	
CHKD: Ricky 2014/03/26		SCALE	SHEET
APPD:		1:1	1/1
		REV. A	CUSTOMER DRAWING