

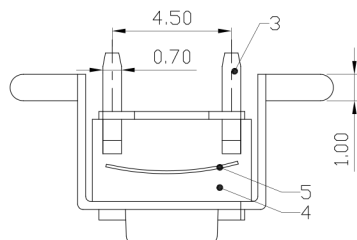

RoHS
Compliant
2002/95/EC

REV.	ECN.	NO.	APPD.

DIMENSIONS



P.C.B MOUNTING PATTERN DIMENSION

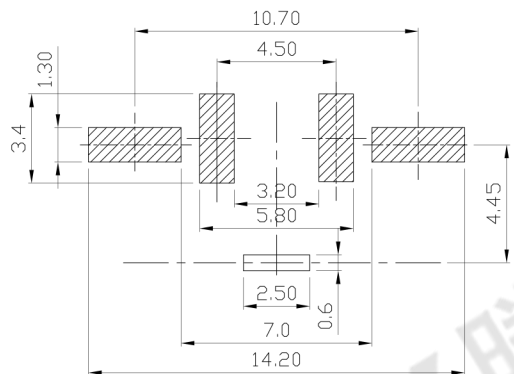

CIRCUIT DIAGRAM

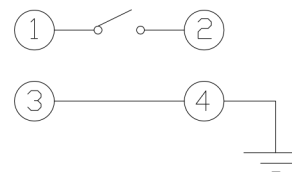

MODEL CODE

AT-1102U12-

	H
-	3.15
A	3.85
B	5.85
D	8.35
C	6.85
F	11.35
E	6.15
CS	6.55
Q	4.85

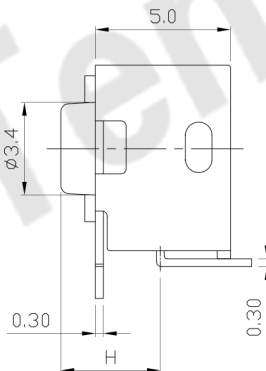
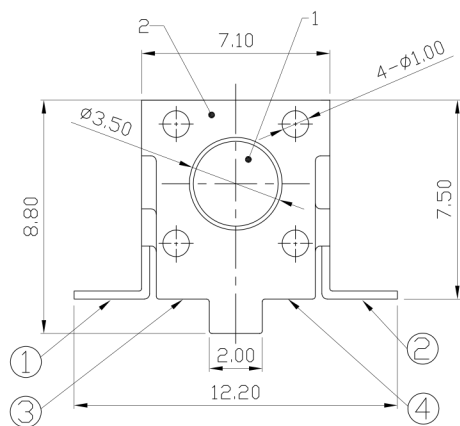

ELECTRO-MECHANICAL CHARACTERISTICS

Refer to additional specifications

Rating	DC 12V 50mA
Contact Resistance	100mΩ Max.
Travel	0.25±0.1mm
Operating Force	100/130/160±50gf 250±100gf
Operating Life(cycles)	100,000

5	CONTACT	PBS/SUS	1	Ag CLAD	WITHIN 1.5mm:±0.1mm	UNITS mm	<p style="text-align: center;">东莞市腾兴电子有限公司</p>								
4	CASE	PPS	1	BLACK	OVER 1.5mm:±0.2mm	MAT'L									
3	TERMINAL	BRASS STRIP	2	Ag PLATED		SEE NOTE									
2	COVER	MILD STEEL	1	Sn PLATED		FINISH									
1	KNOB	PPA	1	BLACK		SEE NOTE									
NO.	PARTS	MATERIAL	Q'TY	FINISHING		Q'TY	<p>THESE DRAWINGS AND SPECIFICATIONS ARE THE PROPERTY OF ACCURATE INNO TECH INC AND SHALL NOT BE REPRODUCED, COPIED OR USED IN ANY MANNER WITHOUT THE PRIOR WRITTEN CONSENT OF ACCURATE INNO TECH INC.</p>								
							<p>TITLE: TACT SWITCH</p> <p>DR: Ricky 2017/08/03</p> <p>CHKD: Ricky 2017/08/03</p> <p>APPD:</p>								
							<p>PART NO.: AT-1102U12 SERIES</p> <p>DWG NO.: AZJ-1102U12</p>								
							<table border="1"> <tr> <th>SCALE</th> <th>SHEET</th> <th>REV.</th> <th>CUSTOMER DRAWING</th> </tr> <tr> <td>6:1</td> <td>1/1</td> <td>A</td> <td></td> </tr> </table>	SCALE	SHEET	REV.	CUSTOMER DRAWING	6:1	1/1	A	
SCALE	SHEET	REV.	CUSTOMER DRAWING												
6:1	1/1	A													