

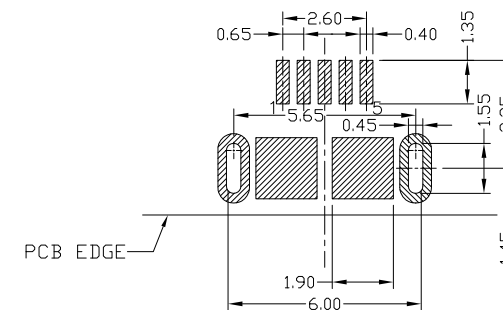

RoHS
Compliant
2002/95/EC

Halogen Free

REV.	ECN.	NO.	APPD.

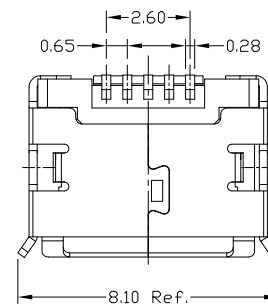
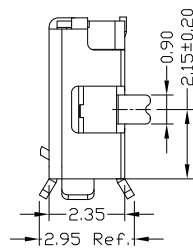
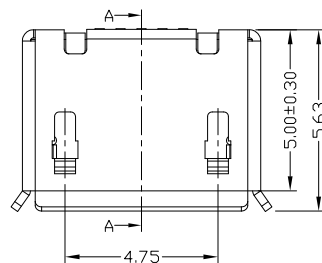
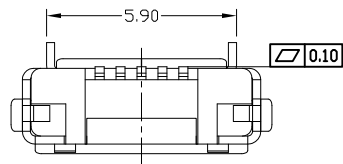

RECOMMENDED PCB LAYOUT

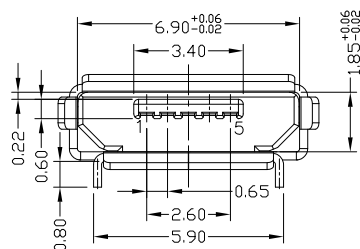

NOTES:

- ELECTRICAL:
 - VOLTAGE CURRENT RATING: PIN1&5 1.8AMP MAX / PIN2&3&4 1AMP MAX. ,30V AC;
 - INSULATION RESISTANCE: 100MΩ MIN;
 - CONTACT RESISTANCE: 30mΩ MAX;
 - WITHSTANDING VOLTAGE: 100V AC; FOR 1 MIN.
 - OPERATING TEMPERATURE: -30°C TO +80°C.
- Mechanical:
 - Mating Force: 35N MAX
 - Unmating Force: 10N MIN.
- DIMENSIONS MARKED "▼" TO BE CHECKED BY Q.C & IPQC.

4.PART NO.

MUZF-05*T-4BHUA161

1:Au 1U*
6:Au 30U*

T:TIN
N:NICKEL

W:WHITE
B:BLACK

1:PBT
2:PA6T
3:PA9T
4:LCP

Bill of materials:

NO	PARTS	MATERIAL	QTY	FINISHING	UNITS	mm	东莞市腾兴电子有限公司						
3	SHELL	COPPER ALLOY	1	PLATED TIN	X. ±0.35	X.* ±2*	MAT'L	TITLE:		PART NO.:			
2	HOUSING	LCP+30%GF	1	UL94V-0	.XX ±0.30	.X* ±1*	SEE NOTE	MICRO USB AB TYPE F 5P 无柱插板5.9		MUZF-05XT-4BHUA161			
1	TERMINAL	COPPER ALLOY	5	PLATED GOLD	.XXX ±0.25	.XX*	FINISH	DR: Ricky 2018/9/3		DWG NO.:			
					.XXX ±0.15	.XXX*	SEE NOTE	CHKD: Ricky 2018/9/3		AII-HUA161			
							Q'TY	APPD:		SCALE	SHEET	REV.	CUSTOMER DRAWING
										5:1	1/1	A	

THESE DRAWINGS AND SPECIFICATIONS ARE THE PROPERTY OF ACCURATE INNTECH INC AND SHALL NOT BE REPRODUCED, COPIED OR USED IN ANY MANNER WITHOUT THE PRIOR WRITTEN CONSENT OF ACCURATE INNTECH INC

