

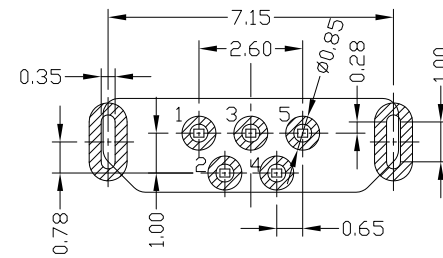

RoHS
Compliant
2002/95/EC

Halogen Free

REV.	ECN.	NO.	APPD.

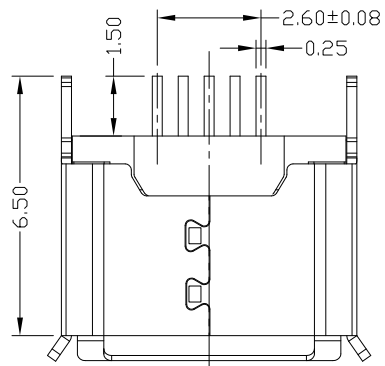
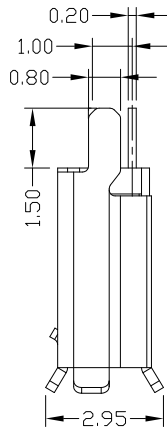
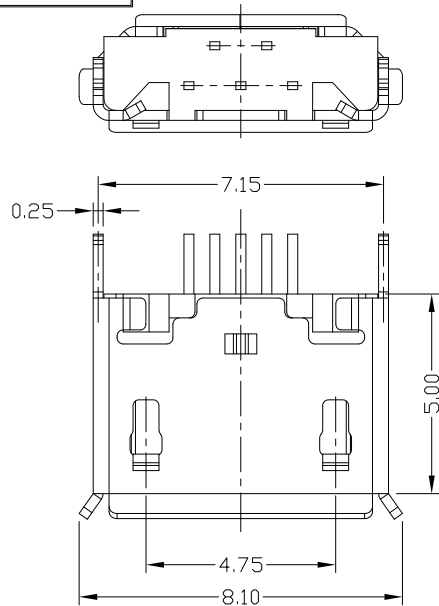

RECOMMENDED PCB LAYOUT

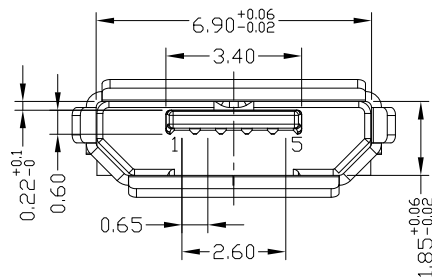

NOTES:

1.ELECTRICAL:

- 1)VOLTAGE CURRENT RATING:PIN1&5 1.8AMP MAX / PIN2&3&4 1AMP MAX. ,30V AC;
- 2)INSULATION RESISTANCE: 100MΩ MIN;
- 3)CONTACT RESISTANCE: 30mΩ MAX;
- 4)WITHSTANDING VOLTAGE: 100V AC; FOR 1 MIN.
- 5)OPERATING TEMPERATURE:-30°C TO +80°C.

2.Mechanical:

- 1)Mating Force: 35N MAX
- 2)Unmating Force: 10N MIN.

3.DIMENSIONS MARKED "▼" TO BE CHECKED BY Q.C & IPQC.

4.PART NO.

MUYF-05*T-4BPUA678

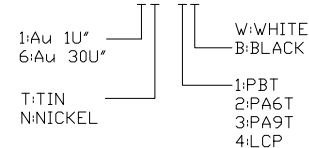

Bill of materials:

NO	PARTS	MATERIAL	QTY	FINISHING	UNITS	mm	东莞市腾兴电子有限公司				
3	SHELL	STAINLESS STEEL	1	PLATED TIN	X. ±0.35	X.' ±2'	SEE NOTE	TITLE: MICRO USB B TYPE F 5P 180度 插板脚长1.5		PART NO.: MUYF-05*T-4BPUA678	
2	HOUSING	LCP+30%GF	1	UL94V-0	.X ±0.30	.X' ±1'		DR: Ricky 2018/3/27	DWG NO.: AII-PUA678		SCALE SHEET REV. CUSTOMER DRAWING
1	TERMINAL	COPPER ALLOY	5	PLATED GOLD	.XX ±0.25	.XX'	FINISH	CHKD: Ricky 2018/3/27		SCALE SHEET REV. CUSTOMER DRAWING	
NO	PARTS	MATERIAL	QTY	FINISHING	.XXX ±0.15	.XXX'	SEE NOTE	APPD:		SCALE SHEET REV. CUSTOMER DRAWING	

THESE DRAWINGS AND SPECIFICATIONS ARE THE PROPERTY OF ACCURATE INDDTECH INC AND SHALL NOT BE REPRODUCED, COPIED OR USED IN ANY MANNER WITHOUT THE PRIOR WRITTEN CONSENT OF ACCURATE INDDTECH INC

