

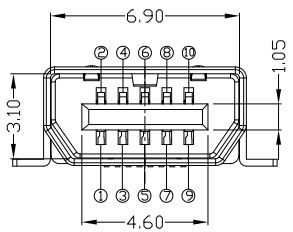

RoHS
Compliant
2002/95/EC

REV.	ECN.	NO.	APPD.

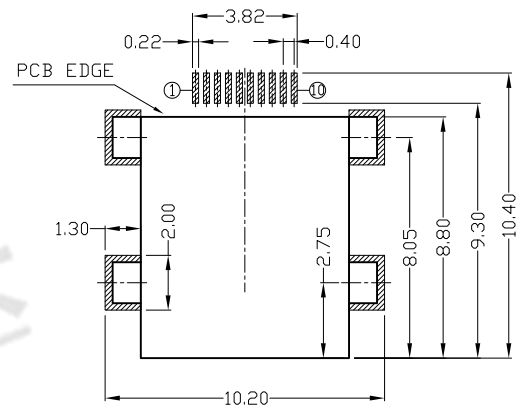
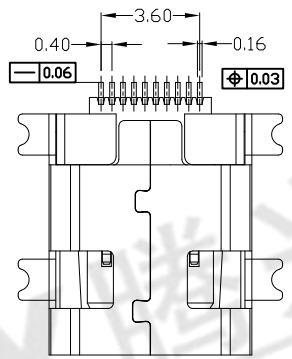
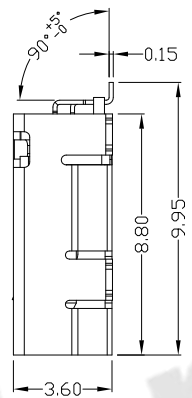
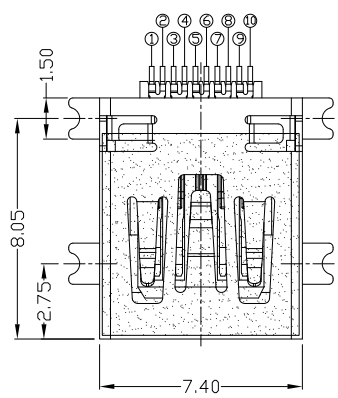
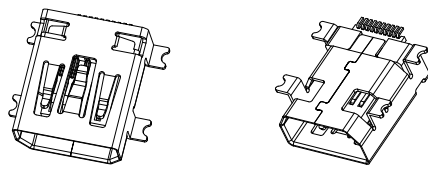
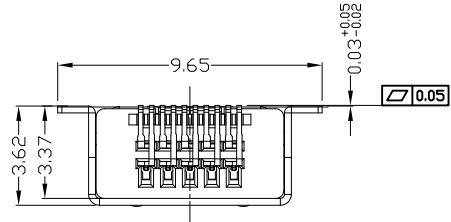

NOTES:

- ELECTRICAL:
 - VOLTAGE CURRENT RATING: 1.0AMP,100V AC;
 - INSULATION RESISTANCE: 100MΩ MIN;
 - CONTACT RESISTANCE: 50mΩ MAX;
 - WITHSTANDING VOLTAGE: 100V AC;
 - OPERATING TEMPERATURE:-30°C TO +80°C.
- Mechanical:
 - Mating Force: 35N MAX
 - Unmating Force: 7N MIN.
- DIMENSIONS MARKED "▼" TO BE CHECKED BY Q.C & IPQC.

4.PART NO.

MUNF-101T-4BVS17-M
 1:Au 1U"
 6:Au 30U"
 1:PBT
 2:PA6T
 3:PA9T
 4:LCP

Bill of materials:

3	HOUSING	LCP+30%GF	1	UL94V-0
2	SHELL	STAINLESS STEEL	1	PLATED TIN
1	TERMINAL	COPPER ALLOY	10	PLATED GOLD/TIN
NO	PARTS	MATERIAL	QTY	FINISHING

X. ±0.35	X.' ±2'	UNITS	mm
.X ±0.3	.X' ±1'	MAT'L	SEE NOTE
.XX ±0.25	.XX'	FINISH	SEE NOTE
.XXX ±0.15	.XXX'	Q'TY	SEE NOTE

东莞市腾兴电子有限公司

TITLE: MINI USB 10PIN PHILIPS 母座AB
TYPE 全贴无柱

PART NO.: MUNF-101T-4BVS17-M

DR: gan 2014/09/25

DWG NO.: AII-VS17-M

CHKD: gan 2014/09/25

APPD:

SCALE	SHEET	REV.	CUSTOMER DRAWING
1:1	1/1	B	

THESE DRAWINGS AND SPECIFICATIONS ARE THE PROPERTY OF ACCURATE INNOTECH INC AND SHALL NOT BE REPRODUCED, COPIED OR USED IN ANY MANNER WITHOUT THE PRIOR WRITTEN CONSENT OF ACCURATE INNOTECH INC.