

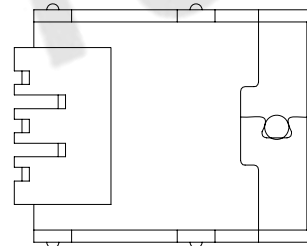

RoHS  
Compliant  
2002/95/EC

REV	LTR	DESCRIPTION	DATE	REVISER	APPD

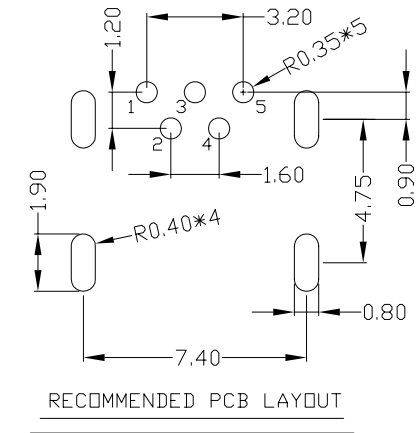
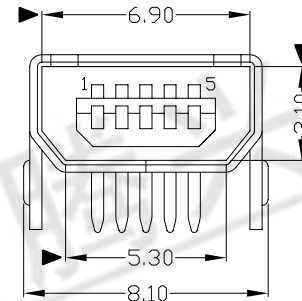
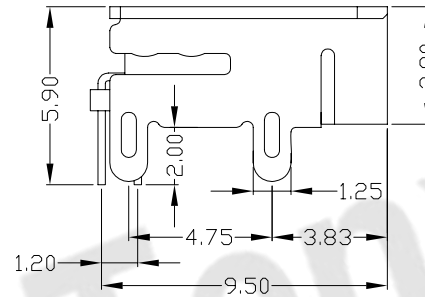
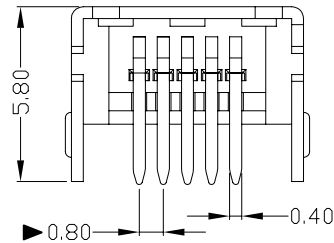
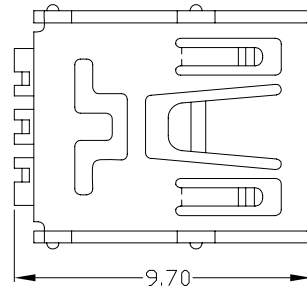

NOTES:

1. ELECTRICAL:

- 1) VOLTAGE CURRENT RATING: 1.0AMP,30V AC;
- 2) INSULATION RESISTANCE: 100MΩ MIN;
- 3) CONTACT RESISTANCE: 50mΩ MAX;
- 4) WITHSTANDING VOLTAGE: 300V AC;
- 5) OPERATING TEMPERATURE:-55°C TO +85°C.

2. Mechanical:

- 1) Mating Force: 30N MAX
- 2) Unmating Force: 7N MIN.

3. DIMENSIONS MARKED "▼" TO BE CHECKED BY Q.C & IPQC.

4.PART NO.

MUNF-05\*N-4BR80  
 1:W/WHITE  
 2:BLACK  
 1:1PBT  
 2:2PA6T  
 3:3PA9T  
 4:LCP  
 1:Au 1U'  
 6:Au 30U'

Bill of materials:

3	HOUSING	LCP	1	UL94V-0	X. ±0.35	X.' ±2*	UNITS	mm	<b>东莞市腾兴电子有限公司</b>							
2	SHELL	COPPER ALLOY	1	PLATED NICKEL	.X ±0.3	.X' ±1*	MAT'L	SEE NOTE					TITLE:	PART NO.:		
1	TERMINAL	COPPER ALLOY	5	PLATED GOLD/TIN	.XX ±0.25	.XX'	FINISH	SEE NOTE					DR:	MUNF-05*N-4BR80		
NO	PARTS	MATERIAL	QTY	FINISHING	.XXX ±0.15	.XXX'	Q'TY	SEE NOTE	CHKD:	DWG NO.:						
<small>THESE DRAWINGS AND SPECIFICATIONS ARE THE PROPERTY OF ACCURATE INNOTECH INC AND SHALL NOT BE REPRODUCED, COPIED OR USED IN ANY MANNER WITHOUT THE PRIOR WRITTEN CONSENT OF ACCURATE INNOTECH INC.</small>									APPD:	AII-R80						
									SCALE	SHEET	REV.	CUSTOMER DRAWING				