

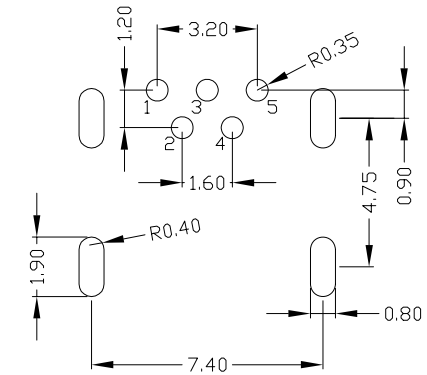

RoHS
Compliant
2002/95/EC

REV.	ECN.	NO.	APPD.

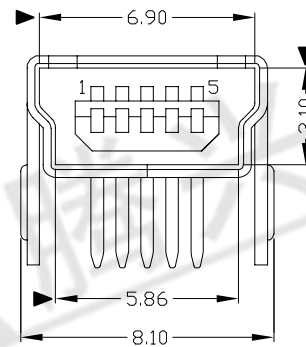
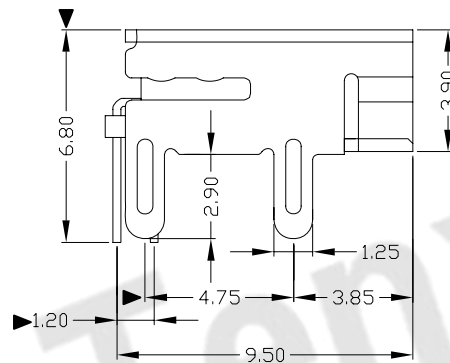
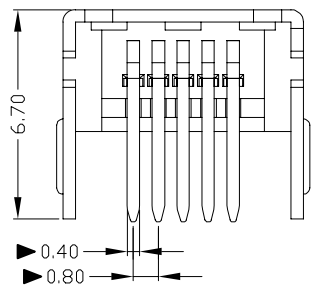
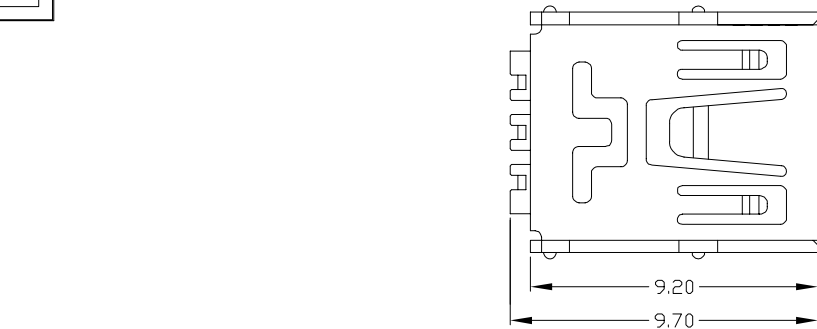

RECOMMENDED PCB LAYOUT

NOTES:

1. ELECTRICAL:

- 1) VOLTAGE CURRENT RATING: 1.0AMP,30V AC;
- 2) INSULATION RESISTANCE: 100MΩ MIN;
- 3) CONTACT RESISTANCE: 50mΩ MAX;
- 4) WITHSTANDING VOLTAGE: 300V AC;
- 5) OPERATING TEMPERATURE:-55°C TO +85°C.

2. Mechanical:

- 1) Mating Force: 30N MAX
- 2) Unmating Force: 7N MIN.

3. DIMENSIONS MARKED "▼" TO BE CHECKED BY Q.C & IPQC.

4.PART NO.

MUBF-05*N-4BR83

1:Au 1U"
6:Au 30U"

W:WHITE
B:BLACK
1:PBT
2:PA6T
3:PA9T
4:LCP

Bill of materials:

NO	PARTS	MATERIAL	QTY	FINISHING	UNITS	mm	东莞市腾兴电子有限公司					
3	HOUSING	LCP	1	UL94V-0	X. ±0.35	X.* ±2*	SEE NOTE	TITLE: MINI USB 5P/F 90° B型 (四脚加长)		PART NO.: MUBF-05*N-4BR83		
2	SHELL	COPPER ALLOY	1	PLATED NICKEL	.X ±0.3	.X* ±1*						
1	TERMINAL	COPPER ALLOY	5	PLATED GOLD/TIN	.XXX ±0.15	.XXX*	FINISH SEE NOTE	CHKD: gan 2012/7/02	SCALE	SHEET	REV.	CUSTOMER DRAWING
					Q'TY		APPD:	1:1	1/1	B		

THESE DRAWINGS AND SPECIFICATIONS ARE THE PROPERTY OF ACCURATE INNOVATECH INC AND SHALL NOT BE REPRODUCED, COPIED OR USED IN ANY MANNER WITHOUT THE PRIOR WRITTEN CONSENT OF ACCURATE INNOVATECH INC.

