

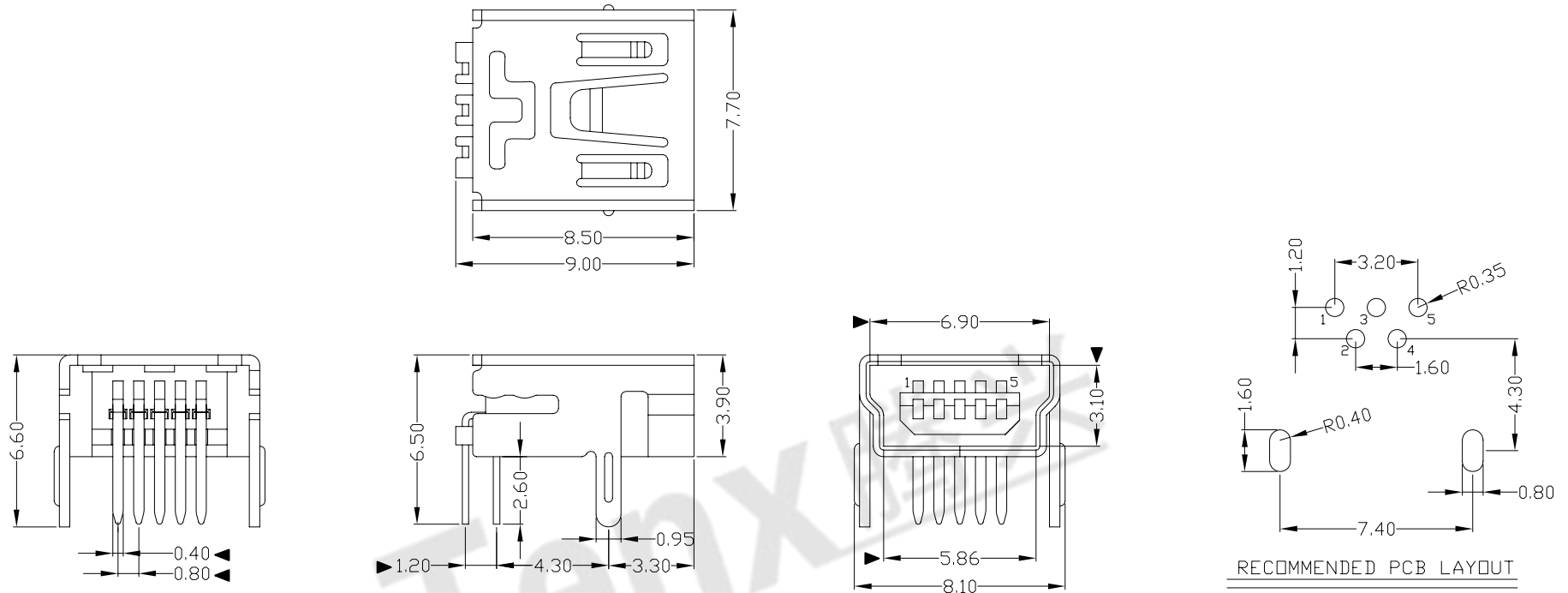

RoHS
Compliant
2002/95/EC

REV.	ECN. NO.	APPD.



NOTES:

- ELECTRICAL:
 - VOLTAGE CURRENT RATING: 1.0AMP,30V AC;
 - INSULATION RESISTANCE: 100MΩ MIN;
 - CONTACT RESISTANCE: 50mΩ MAX;
 - WITHSTANDING VOLTAGE: 300V AC;
 - OPERATING TEMPERATURE:-55°C TO +85°C.
- Mechanical:
 - Mating Force: 30N MAX
 - Unmating Force: 7N MIN.
- DIMENSIONS MARKED "▼" TO BE CHECKED BY Q.C & IPQC.

4.PART NO.

MUBF-05*N-4BR86
 1:1Au 1U*
 6:4Au 30U*
 W:WHITE
 B:BLACK
 1:PBT
 2:PA6T
 3:PA9T
 4:LCP

Bill of materials:

NO	PARTS	MATERIAL	QTY	FINISHING	UNITS	mm	东莞市腾兴电子有限公司						
3	HOUSING	LCP	1	UL94V-0	X. ±0.35	X.* ±2*	MAT'L	TITLE:		PART NO.:			
2	SHELL	COPPER ALLOY	1	PLATED NICKEL	.XX ±0.25	.XX*	SEE NOTE	MINI USB 5P/F 90° B型(两脚加长)		MUBF-05*N-4BR86			
1	TERMINAL	COPPER ALLOY	5	PLATED GOLD/TIN	.XXX ±0.15	.XXX*	FINISH	DR: gan 2012/7/02		DWG NO.:			
THESE DRAWINGS AND SPECIFICATIONS ARE THE PROPERTY OF ACCURATE INNOTECH INC AND SHALL NOT BE REPRODUCED, COPIED OR USED IN ANY MANNER WITHOUT THE PRIOR WRITTEN CONSENT OF ACCURATE INNOTECH INC.							SEE NOTE	CHKD: gan 2012/7/02		AII-R86			
							Q'TY	APPD:		SCALE	SHEET	REV.	CUSTOMER DRAWING
										1:1	1/1	B	