

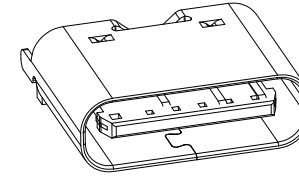

RoHS
Compliant
2002/95/EC

REV.	ECN.	NO.	APPD.

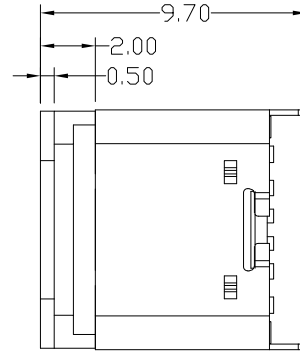
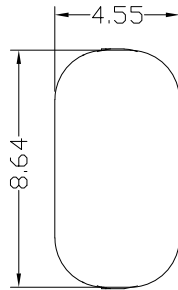
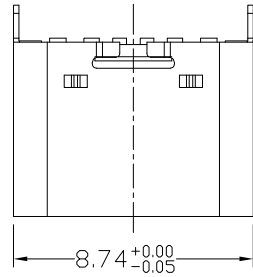

加胶帽示意图

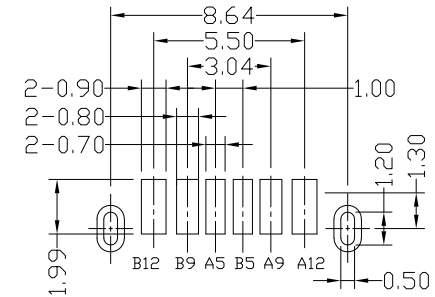
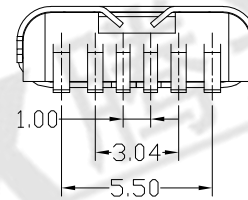
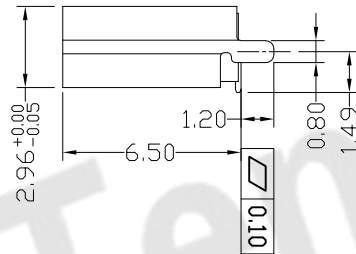
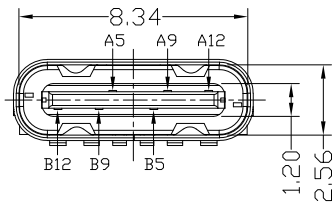

RECOMMENDED P.C.B. LAYOUT
TOLERANCE UNSPECIFIED ±0.05mm

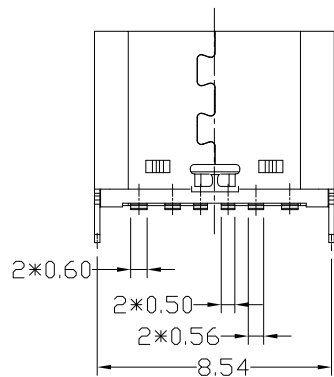

A5	CC1	B12	GND
A9	VBUS	B9	VBUS
A12	GND	B5	CC2
PIN	SIGNAL NAME	PIN	SIGNAL NAME

NOTES:

1.ELECTRICAL:

- CURRENT RATING: 3A MAX.
- INSULATION RESISTANCE: 100MΩ MIN;
- CONTACT RESISTANCE: 40mΩ MAX;
- WITHSTANDING VOLTAGE: 100V AC
- OPERATING TEMPERATURE: -30°C TO +85°C.

2.Mechanical:

- Mating Force: 5N~20N
- Unmating Force: 8N~20N
- Durability: 10,000 cycles

3.DIMENSIONS MARKED "▼"
TO BE CHECKED BY Q.C & IPQC.

4.PART NO.

USCF-06*N-4BQS22

1Au 1U'
2Au 3U'
5Au 15U'
6Au 30U'
1PBT
2PA6T
3PA9T
4LCP

5	COVER	LCP+30%GF	1	UL94V-0	.X ±0.30	.X' ±2'	UNITS	mm
4	SHIELDING PLATE	STAINLESS STEEL	1		.XX ±0.20	.XX' ±1'	MAT'L	
3	SHELL	STAINLESS STEEL	1	PLATED NICKEL	.XXX ±0.10	.XXX' ±0.5'	SEE NOTE	
2	CONTACT	COPPER ALLOY	6	PLATED GOLD/TIN			SEE NOTE	
1	HOUSING	LCP+30%GF	1	UL94V-0			Q'TY	
NO	PARTS	MATERIAL	QTY	FINISHING				

THESE DRAWINGS AND SPECIFICATIONS ARE THE PROPERTY OF ACCURATE INNOTECH INC AND SHALL NOT BE REPRODUCED, COPIED OR USED IN ANY MANNER WITHOUT THE PRIOR WRITTEN CONSENT OF ACCURATE INNOTECH INC

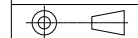

东莞市腾兴电子有限公司

TITLE:	USB Type-CF 6P 直立式SMT	PART NO.:	USCF-06XN-4BQS22
DR:	Ricky 2019/08/16	DWG NO.:	AII-QS22
CHKD:	Ricky 2019/08/16	SCALE	1:1
APPD:		SHEET	1/1
		REV.	B
		CUSTOMER DRAWING	