

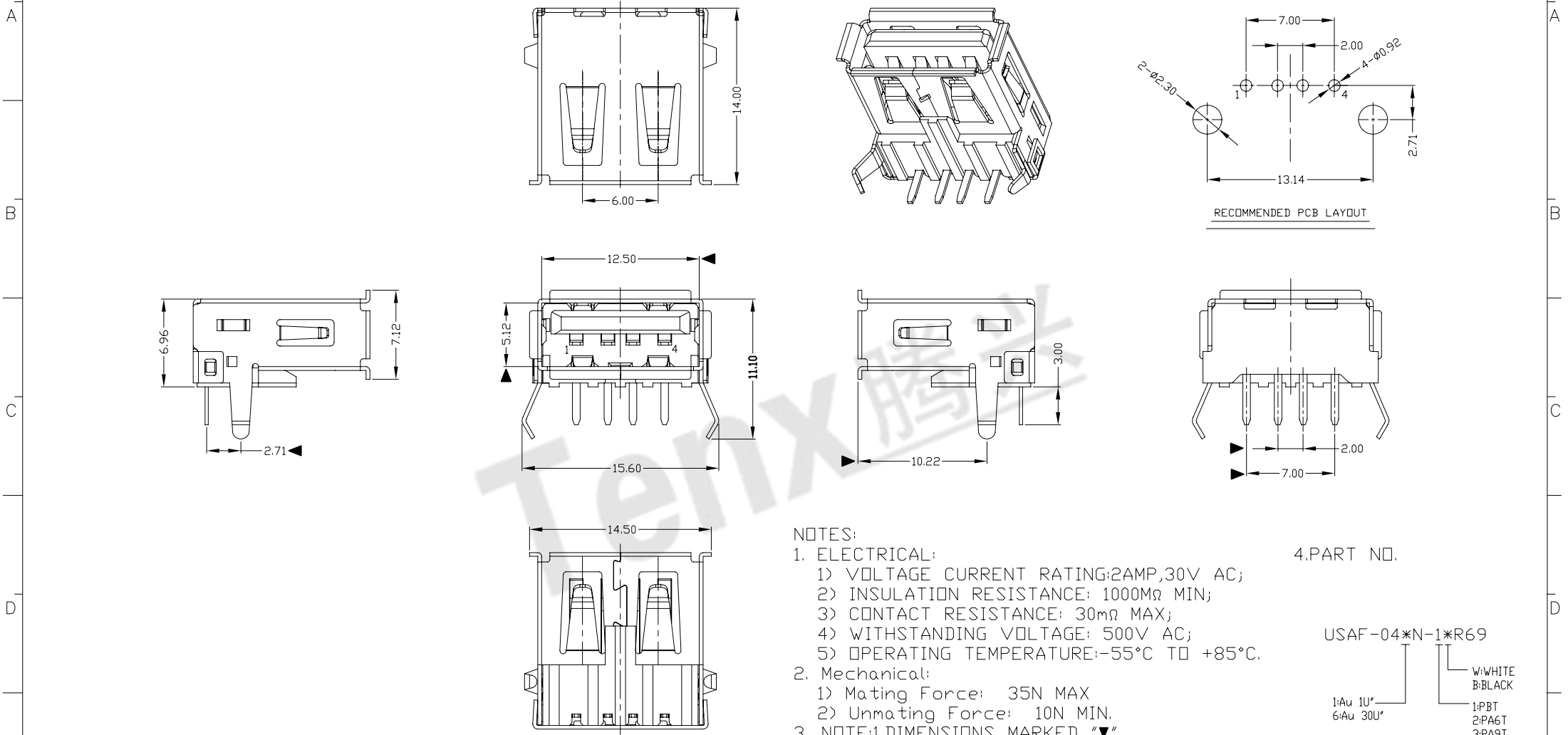

RoHS
Compliant
2002/95/EC

REV.	ECN.	NO.	APPD.



- NOTES:
- ELECTRICAL:
 - VOLTAGE CURRENT RATING: 2AMP, 30V AC;
 - INSULATION RESISTANCE: 1000M Ω MIN;
 - CONTACT RESISTANCE: 30m Ω MAX;
 - WITHSTANDING VOLTAGE: 500V AC;
 - OPERATING TEMPERATURE: -55°C TO +85°C.
 - Mechanical:
 - Mating Force: 35N MAX
 - Unmating Force: 10N MIN.
 - NOTE: 1. DIMENSIONS MARKED "▼" TO BE CHECKED BY Q.C & IPQC.

4. PART NO.

USAF-04*N-1*R69

1: Au 1U"
6: Au 30U"

W: WHITE
B: BLACK

1: PBT
2: PA6T
3: PA9T
4: LCP

Bill of materials:

NO	PARTS	MATERIAL	QTY	FINISHING	UNITS	mm	TITLE:	PART NO.:
3	HOUSING	PBT	1	UL94V-0	X. \pm 0.35	X.' \pm 2'	USB A/F 90° DIP 弯脚 外扣	USAF-04*N-1*R69
2	SHELL	COPPER ALLOY	1	PLATED NICKEL	.X \pm 0.3	.X' \pm 1'	DR: gan 2012/6/29	DWG NO.: AII-R69
1	TERMINAL	COPPER ALLOY	4	PLATED GOLD/TIN	.XX \pm 0.25	.XX'	CHKD: gan 2012/6/29	SCALE SHEET REV. CUSTOMER DRAWING
					.XXX \pm 0.15	.XXX'	APPD:	1:1 1/1 B

THESE DRAWINGS AND SPECIFICATIONS ARE THE PROPERTY OF ACCURATE INNOTECH INC AND SHALL NOT BE REPRODUCED, COPIED OR USED IN ANY MANNER WITHOUT THE PRIOR WRITTEN CONSENT OF ACCURATE INNOTECH INC.

