

REV.	ECN.	NO.	APPD.

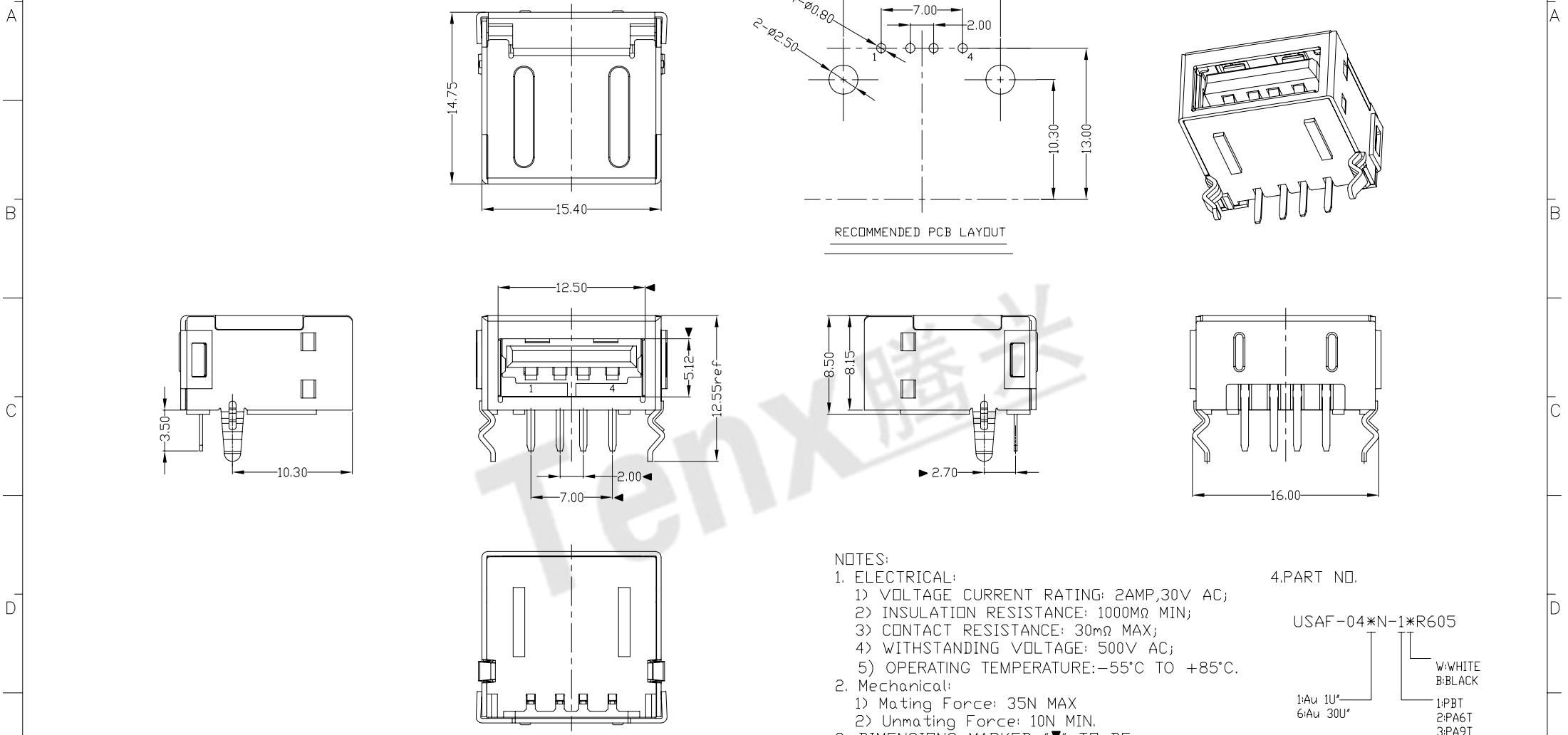

- NOTES:**
- ELECTRICAL:**
 - VOLTAGE CURRENT RATING: 2AMP,30V AC;
 - INSULATION RESISTANCE: 1000MΩ MIN;
 - CONTACT RESISTANCE: 30mΩ MAX;
 - WITHSTANDING VOLTAGE: 500V AC;
 - OPERATING TEMPERATURE: -55°C TO +85°C.
 - Mechanical:**
 - Mating Force: 35N MAX
 - Unmating Force: 10N MIN.
 - DIMENSIONS MARKED "▼" TO BE CHECKED BY Q.C & IPQC.

4.PART NO.

USAF-04*N-1*R605

1:Au 1U"
6:Au 30U"

W:WHITE
B:BLACK

1:PBT
2:PA6T
3:PA9T
4:LCP

Bill of materials:

NO	PARTS	MATERIAL	QTY	FINISHING	X. ±0.35	X.' ±2°	UNITS	mm
5	CLIP	STAINLESS STEEL	1					
4	BACK COVER	SPCC	1	PLATED NICKEL	.X ±0.3	.X' ±1°	MAT'L	
3	HOUSING	PBT	1	UL94V-0	.XX ±0.25	.XX'	SEE NOTE	
2	SHELL	SPCC	1	PLATED NICKEL	.XXX ±0.15	.XXX'	FINISH	
1	TERMINAL	COPPER ALLOY	4	PLATED GOLD/TIN			SEE NOTE	
							Q'TY	

THESE DRAWINGS AND SPECIFICATIONS ARE THE PROPERTY OF ACCURATE INNOTECH INC AND SHALL NOT BE REPRODUCED, COPIED OR USED IN ANY MANNER WITHOUT THE PRIOR WRITTEN CONSENT OF ACCURATE INNOTECH INC.

东莞市腾兴电子有限公司

TITLE:	USB AF 单层全包 90°	PART NO.:	USAF-04*N-1*R605
DR:	gan 2012/6/29	DWG NO.:	AII-R605
CHKD:	gan 2012/6/29	SCALE	1:1
APPD:		SHEET	1/1
		REV.	B
		CUSTOMER DRAWING	