

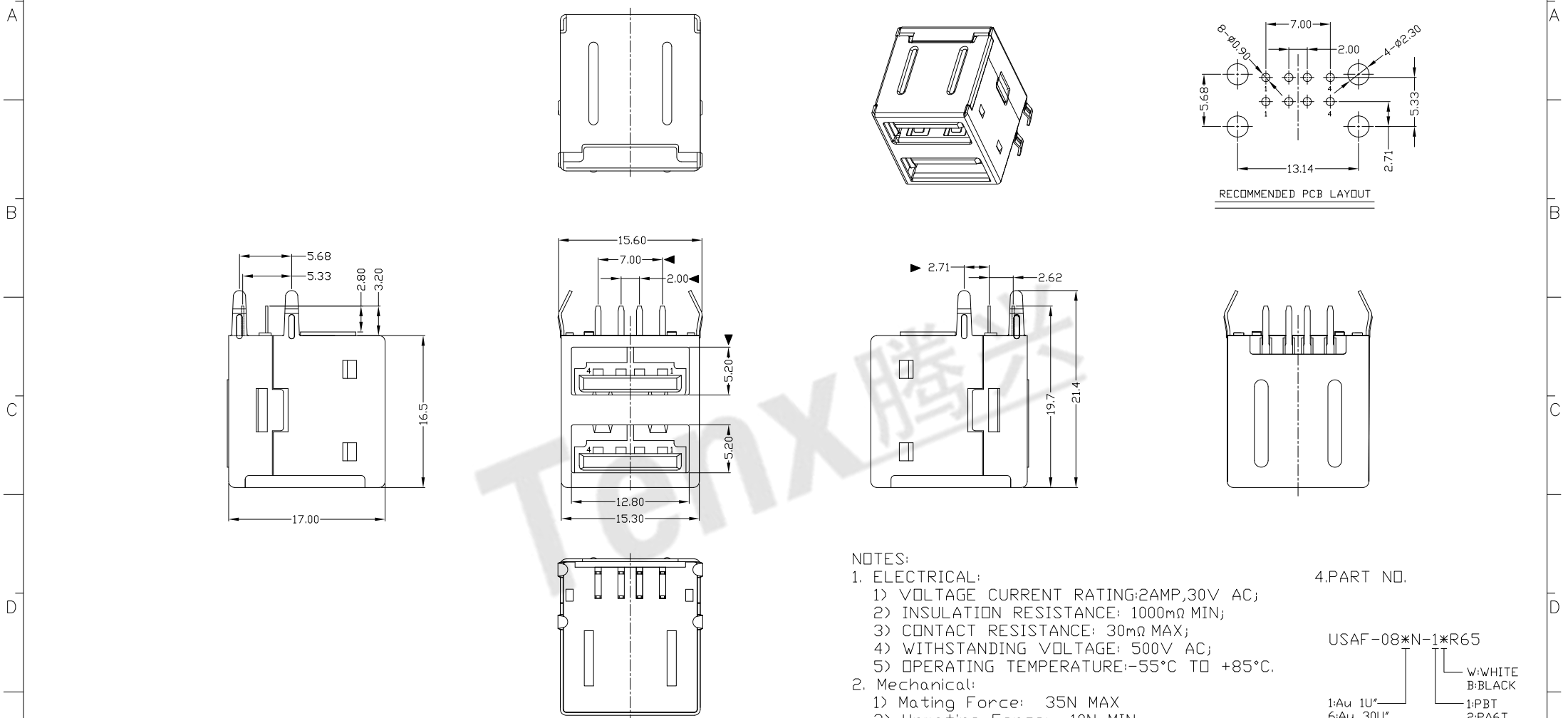

RoHS  
Compliant  
2002/95/EC

REV.	ECN.	NO.	APPD.



NOTES:

- ELECTRICAL:
  - VOLTAGE CURRENT RATING: 2AMP, 30V AC;
  - INSULATION RESISTANCE: 1000mΩ MIN;
  - CONTACT RESISTANCE: 30mΩ MAX;
  - WITHSTANDING VOLTAGE: 500V AC;
  - OPERATING TEMPERATURE: -55°C TO +85°C.
- Mechanical:
  - Mating Force: 35N MAX
  - Unmating Force: 10N MIN.
- NOTE: 1. DIMENSIONS MARKED "▼" TO BE CHECKED BY Q.C & IPQC.

4. PART NO.

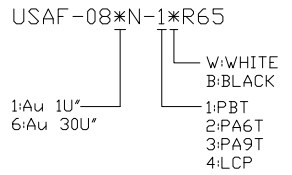

Bill of materials:

NO	PARTS	MATERIAL	QTY	FINISHING
5	CLIP	STAINLESS STEEL	1	
4	BACK COVER	SPCC	1	PLATED NICKEL
3	HOUSING	PBT	1	UL94V-0
2	SHELL	SPCC	1	PLATED NICKEL
1	TERMINAL	COPPER ALLOY	8	PLATED GOLD/TIN

X. ±0.35	X.' ±2'	UNITS	mm
.X ±0.3	.X' ±1'	MAT'L	
.XX ±0.25	.XX'	SEE NOTE	
.XXX ±0.15	.XXX'	FINISH	
		SEE NOTE	
		Q'TY	

THESE DRAWINGS AND SPECIFICATIONS ARE THE PROPERTY OF ACCURATE INNOVATION AND SHALL NOT BE REPRODUCED, COPIED OR USED IN ANY MANNER WITHOUT THE PRIOR WRITTEN CONSENT OF ACCURATE INNOVATION INC.

<b>东莞市腾兴电子有限公司</b>			
TITLE:		PART NO.:	
USB AF 90° DIP双层全包 无弹长脚		USAF-08*N-1*R65	
DR: <i>Ricky</i> 2014/04/15		DWG NO.:	
CHKD: <i>Ricky</i> 2014/04/15		AII-R65	
APPD:	SCALE	SHEET	REV.
	1:1	1/1	B
			CUSTOMER DRAWING