

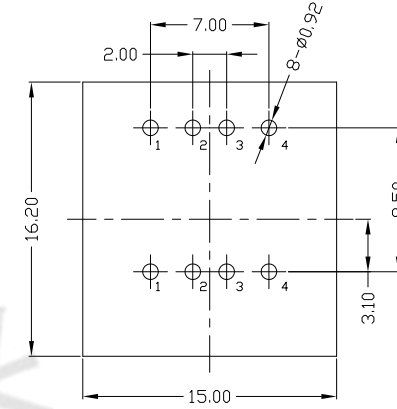

RoHS  
Compliant  
2002/95/EC

REV.	ECN.	NO.	APPD.

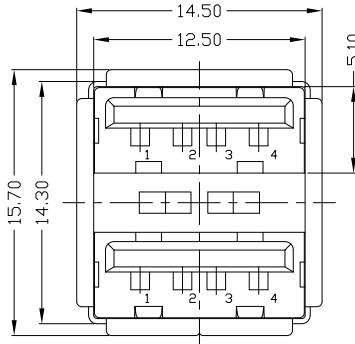
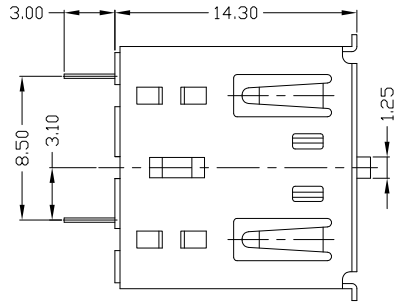

RECOMMENDED PCB LAYOUT

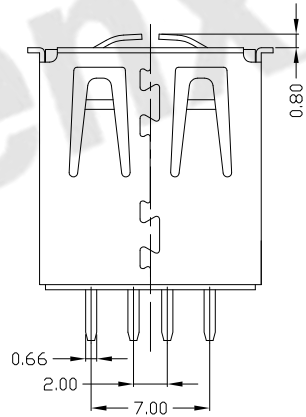

NOTES:

- ELECTRICAL:
  - VOLTAGE CURRENT RATING: 2AMP, 30V AC;
  - INSULATION RESISTANCE: 1000MΩMIN;
  - CONTACT RESISTANCE: 30mΩMAX;
  - WITHSTANDING VOLTAGE: 500V AC;
  - OPERATING TEMPERATURE: -55°C TO +85°C.
- Mechanical:
  - Mating Force: 35N MAX
  - Unmating Force: 10N MIN.
- DIMENSIONS MARKED '▼' TO BE CHECKED BY Q.C & IPQC.

4. PART NO.

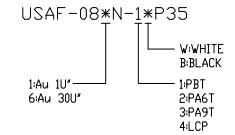

Bill of materials:

NO	PARTS	MATERIAL	QTY	FINISHING	UNITS	mm	东莞市腾兴电子有限公司					
4	CLIP	COPPER ALLOY	1	PLATED NICKEL	X. ±0.35	X.' ±2'	SEE NOTE	TITLE:		PART NO.:		
3	HOUSING	PBT+30%GF	1	UL94V-0	.X ±0.3	.X' ±1'		USB AF 180° 双层插板短体 (双弹) 成品		USAF-08*N-1*P35		
2	SHELL	COPPER ALLOY	1	PLATED NICKEL	.XX ±0.25	.XX'		DR: gan 2014/09/26		DWG NO.:		
1	TERMINAL	COPPER ALLOY	8	PLATED GOLD/TIN	.XXX ±0.15	.XXX'	SEE NOTE	CHKD: gan 2014/09/26		AII-P35		
				THESE DRAWINGS AND SPECIFICATIONS ARE THE PROPERTY OF ACCURATE INNOVATECH INC AND SHALL NOT BE REPRODUCED, COPIED OR USED IN ANY MANNER WITHOUT THE PRIOR WRITTEN CONSENT OF ACCURATE INNOVATECH INC.		Q'TY	APPD:	SCALE	SHEET	REV.	CUSTOMER DRAWING	
							1:1	1/1	B			