

REV	LTR	DESCRIPTION	DATE	REVISER	APPD

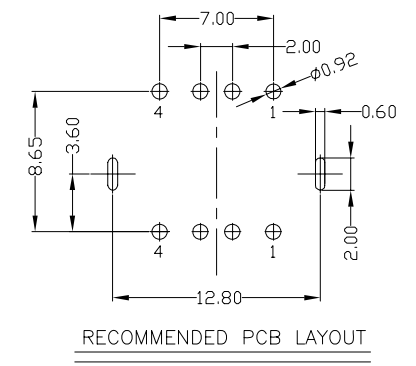
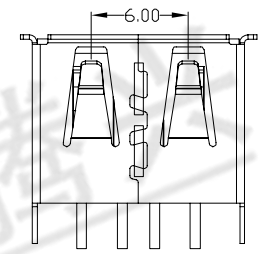
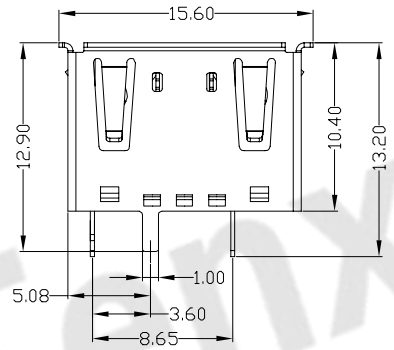
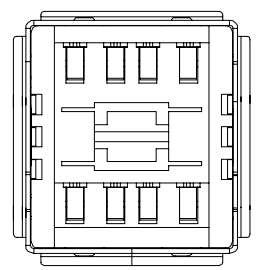
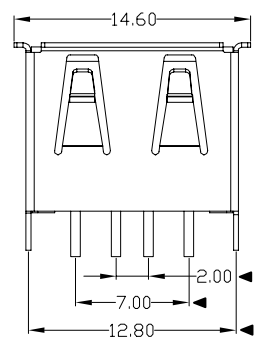
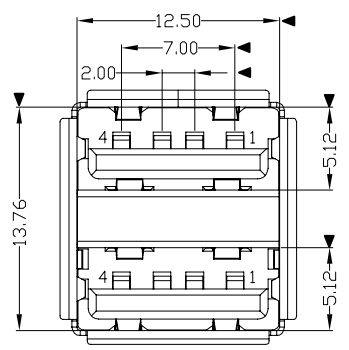

- NOTES:
- ELECTRICAL:
 - VOLTAGE CURRENT RATING: 2AMP, 30V AC;
 - INSULATION RESISTANCE: 1000MΩ MIN;
 - CONTACT RESISTANCE: 30mΩ MAX;
 - WITHSTANDING VOLTAGE: 500V AC;
 - OPERATING TEMPERATURE: -55°C TO +85°C.
 - Mechanical:
 - Mating Force: 35N MAX
 - Unmating Force: 10N MIN.
 - NOTE: 1. DIMENSIONS MARKED "▼" TO BE CHECKED BY Q.C & IPQC.

4. PART NO.
 USAF-08*N-1*PU00
 1: Au 1U*
 6: Au 30U*
 W: WHITE
 B: BLACK
 1: PBT
 2: PA6T
 3: PA9T
 4: LCP

Bill of materials:

NO	PARTS	MATERIAL	QTY	FINISHING	X. ±0.35	X.* ±2*	UNITS	mm
4	CLIP	SPCC	1	PLATED NICKEL	.X ±0.3	.X* ±1*	MAT'L	
3	HOUSING	PBT	1	UL94V-0	.XX ±0.25	.XX*	SEE NOTE	
2	SHELL	COPPER ALLOY	1	PLATED NICKEL	.XXX ±0.15	.XXX*	FINISH	
1	TERMINAL	COPPER ALLOY	8	PLATED GOLD/TIN			SEE NOTE	
					<small>THESE DRAWINGS AND SPECIFICATIONS ARE THE PROPERTY OF ACCURATE INNOVATECH INC AND SHALL NOT BE REPRODUCED, COPIED OR USED IN ANY MANNER WITHOUT THE PRIOR WRITTEN CONSENT OF ACCURATE INNOVATECH INC.</small>			
							Q'TY	

东莞市腾兴电子有限公司

TITLE: USB AF 双层180无弹成品	PART NO.: USAF-08XN-1XPU00
DR: gan 2012/7/05	DWG NO.: AII-PU00
CHKD: gan 2012/7/05	SCALE SHEET REV. CUSTOMER DRAWING
APPD:	1:1 1/1 B