

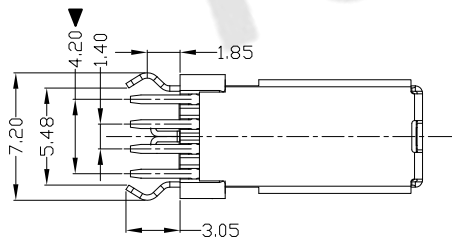

RoHS  
Compliant  
2002/95/EC

REV.	ECN.	NO.	APPD.

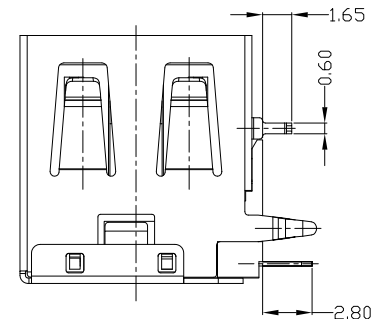
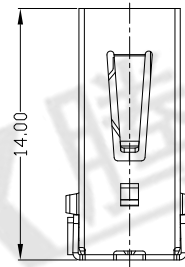
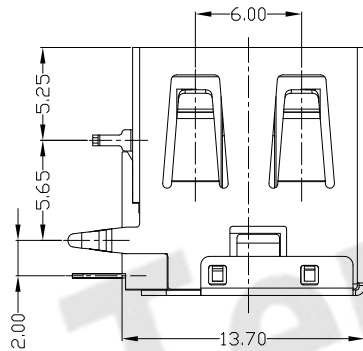
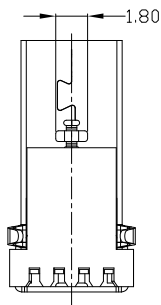
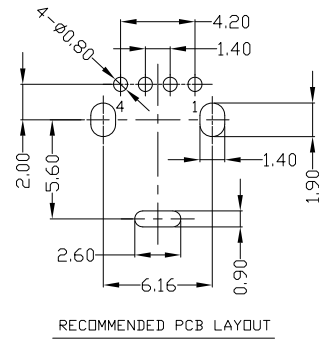
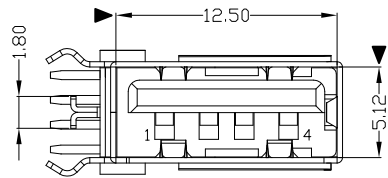

NOTES:

1. ELECTRICAL:

- 1) VOLTAGE CURRENT RATING: 2AMP, 30V AC;
- 2) INSULATION RESISTANCE: 1000M ΩMIN;
- 3) CONTACT RESISTANCE: 30m ΩMAX;
- 4) WITHSTANDING VOLTAGE: 500V AC;
- 5) OPERATING TEMPERATURE: -55°C TO +85°C.

2. Mechanical:

- 1) Mating Force: 35N MAX
- 2) Unmating Force: 10N MIN.

3. NOTE: 1. DIMENSIONS MARKED "▼" TO BE CHECKED BY Q.C & IPQC.

4. PART NO.

USAF-04\*N-1\*C69

1: Au 1U'  
6: Au 30U'

W: WHITE  
B: BLACK  
1: PBT  
2: PA6T  
3: PA9T  
4: LCP

Bill of materials:

NO	PARTS	MATERIAL	QTY	FINISHING	X. ±0.35	X.' ±2'	UNITS	东莞市腾兴电子有限公司				
4	BACK COVER	COPPER ALLOY	1	PLATED NICKEL	.X ±0.35	.X' ±2'	mm	<b>东莞市腾兴电子有限公司</b> TITLE: USB AF 90° DIP 侧插三只脚 无卷边无缺口 PART NO.: USAF-04*N-1*C69 DR: gan 2014/6/18 DWG NO.: AII-C69 CHKD: gan 2014/6/18 APPD:				
3	HOUSING	PBT	1	UL94V-0	.X ±0.3	.X' ±1'	MAT'L					
2	SHELL	COPPER ALLOY	1	PLATED NICKEL	.XX ±0.25	.XX'	SEE NOTE					
1	TERMINAL	COPPER ALLOY	4	PLATED GOLD/TIN	.XXX ±0.15	.XXX'	FINISH					
NO	PARTS	MATERIAL	QTY	FINISHING	THESE DRAWINGS AND SPECIFICATIONS ARE THE PROPERTY OF ACCURATE INNOTECH INC AND SHALL NOT BE REPRODUCED, COPIED OR USED IN ANY MANNER WITHOUT THE PRIOR WRITTEN CONSENT OF ACCURATE INNOTECH INC.			Q'TY	SCALE	SHEET	REV.	CUSTOMER DRAWING
								1:1	1/1	B		