

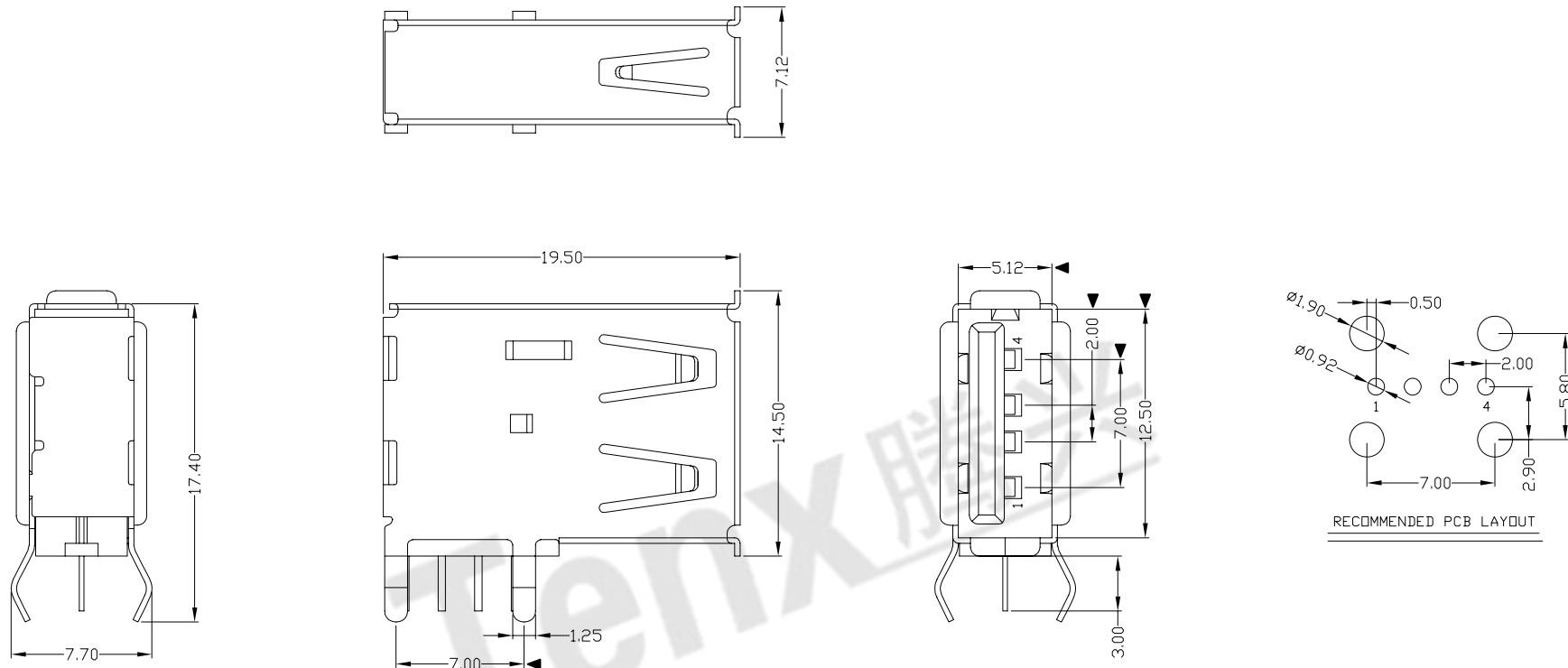

RoHS
Compliant
2002/95/EC

REV.	ECN. NO.	APPD.



NOTES:

- ELECTRICAL:
 - VOLTAGE CURRENT RATING: 2AMP, 30V AC;
 - INSULATION RESISTANCE: 1000MΩ MIN;
 - CONTACT RESISTANCE: 30mΩ MAX;
 - WITHSTANDING VOLTAGE: 500V AC;
 - OPERATING TEMPERATURE: -55°C TO +85°C.
- Mechanical:
 - Mating Force: 35N MAX
 - Unmating Force: 10N MIN.
- NOTE: 1. DIMENSIONS MARKED "▼" TO BE CHECKED BY Q.C & IPQC.

4. PART NO.

USAF-04*N-1*C82

1: Au 1U"
6: Au 30U"

W: WHITE
B: BLACK

1: PBT
2: PA6T
3: PA9T
4: LCP

Bill of materials:

NO	PARTS	MATERIAL	QTY	FINISHING	X.	X.*±2"	UNITS	mm
5	BOTTOM COVER	PBT+30%GF	1	UL94V-0	X. ±0.35	X.* ±2"	UNITS	mm
4	HOUSING	PBT+30%GF	1	UL94V-0	.X ±0.3	.X* ±1"	MAT'L	
3	BACK COVER	SPCC	1	PLATED NICKEL	.XX ±0.25	.XX*	SEE NOTE	
2	SHELL	COPPER ALLOY/SPCC	1	PLATED NICKEL	.XXX ±0.15	.XXX*	SEE NOTE	
1	TERMINAL	COPPER ALLOY	4	Plated Gold in Mating Area; Tin on Solder Tails			Q'TY	

THESE DRAWINGS AND SPECIFICATIONS ARE THE PROPERTY OF ACCURATE INNGTECH INC. AND SHALL NOT BE REPRODUCED, COPIED OR USED IN ANY MANNER WITHOUT THE PRIOR WRITTEN CONSENT OF ACCURATE INNGTECH INC.

东莞市腾兴电子有限公司			
TITLE: USB AF 90度 加后包(弯脚7.70 带后塞) 侧插长体		PART NO.: USAF-04*N-1*C82	
DR: gan 2012/12/13		DWG NO.: AII-C82	
CHKD: gan 2012/12/13		SCALE	SHEET
APPD:		1:1	1/1
		REV.	CUSTOMER DRAWING
		B	