

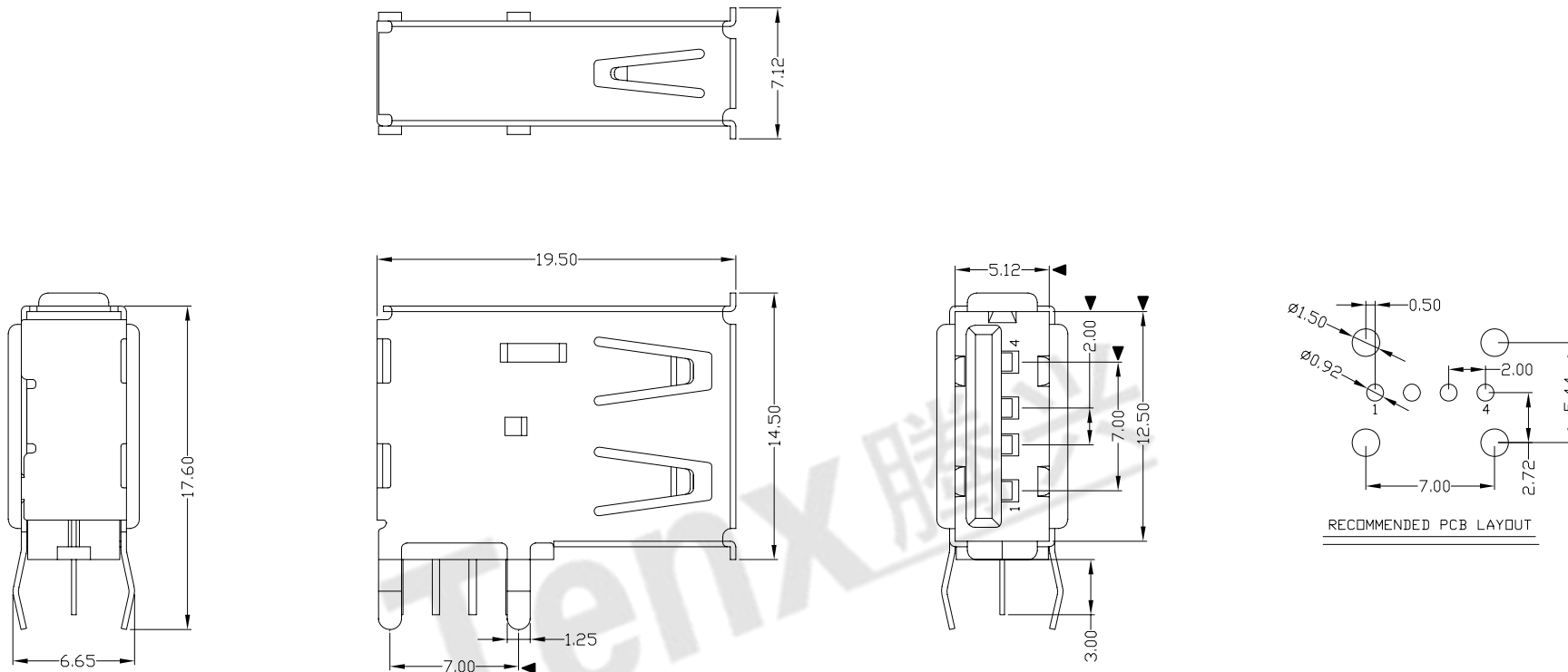

RoHS
Compliant
2002/95/EC

REV.	ECN.	NO.	APPD.



NOTES:

- ELECTRICAL:
 - VOLTAGE CURRENT RATING: 2AMP, 30V AC;
 - INSULATION RESISTANCE: 1000MΩ MIN;
 - CONTACT RESISTANCE: 30mΩ MAX;
 - WITHSTANDING VOLTAGE: 500V AC;
 - OPERATING TEMPERATURE: -55°C TO +85°C.
- Mechanical:
 - Mating Force: 35N MAX
 - Unmating Force: 10N MIN.
- NOTE: 1. DIMENSIONS MARKED "▼" TO BE CHECKED BY Q.C & IPQC.

4. PART NO.

USAF-04*N-1*C83

1: Au 1U"
6: Au 30U"

W: WHITE
B: BLACK
1: PBT
2: PA6T
3: PA9T
4: LCP

Bill of materials:

NO	PARTS	MATERIAL	QTY	FINISHING	X.	X.* ±2*	UNITS	mm	东莞市腾兴电子有限公司			
5	BOTTOM COVER	PBT+30%GF	1	UL94V-0	X. ±0.35	X.* ±2*	UNITS	mm	TITLE: USB AF 90度 加后包(弯脚6.65、带后塞) 侧插长体 PART NO.: USAF-04*N-1*C83 DWG NO.: AII-C83 DR: gan 2012/12/13 CHKD: gan 2012/12/13 APPD:			
4	HOUSING	PBT+30%GF	1	UL94V-0	.X ±0.3	.X* ±1*	MAT'L	SEE NOTE				
3	BACK COVER	SPCC	1	PLATED NICKEL	.XX ±0.25	.XX*	FINISH	SEE NOTE				
2	SHELL	COPPER ALLOY/SPCC	1	PLATED NICKEL	.XXX ±0.15	.XXX*	Q'TY	SEE NOTE				
1	TERMINAL	COPPER ALLOY	4	Plated Gold in Mating Area; Tin on Solder Tails	THESE DRAWINGS AND SPECIFICATIONS ARE THE PROPERTY OF ACCURATE INNDTECH INC. AND SHALL NOT BE REPRODUCED, COPIED OR USED IN ANY MANNER WITHOUT THE PRIOR WRITTEN CONSENT OF ACCURATE INNDTECH INC.			SCALE	SHEET	REV.	CUSTOMER DRAWING	
NO	PARTS	MATERIAL	QTY	FINISHING				1:1	1/1	B		