

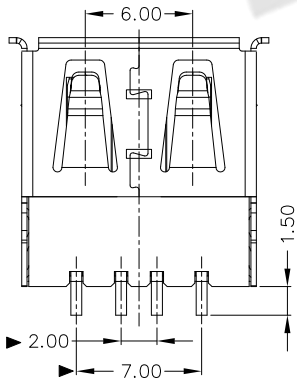

RoHS
Compliant
2002/95/EC

REV.	ECN.	NO.	APPD.

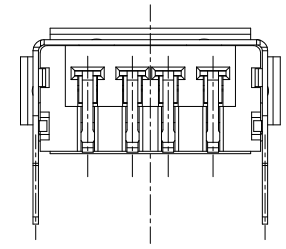
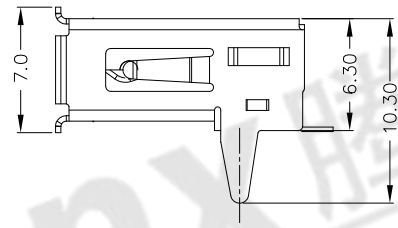
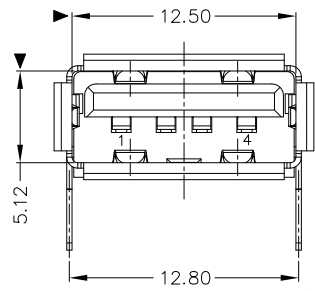
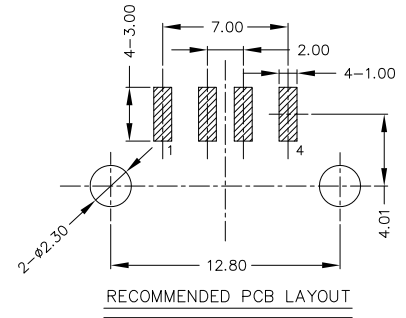
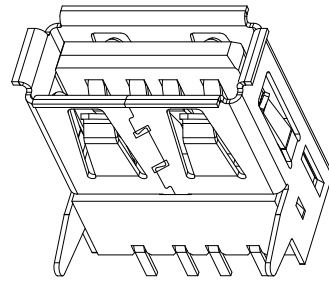
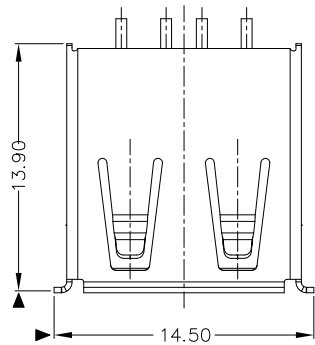

NOTES:

- ELECTRICAL:
 - VOLTAGE CURRENT RATING: 2AMP, 30VAC;
 - INSULATION RESISTANCE: 1000MΩ, MIN;
 - CONTACT RESISTANCE: 30mΩ MAX;
 - WITHSTANDING VOLTAGE: 500V AC;
 - OPERATING TEMPERATURE: -55°C TO +85°C.
- Mechanical:
 - Mating Force: 35N MAX
 - Unmating Force: 10N MIN.
- NOTE: 1. DIMENSIONS MARKED "▼" TO BE CHECKED BY Q.C & IPQC.

4. PART NO.

USAF-04*N-4*V602

1: Au 1U"
6: Au 30U"

W: WHITE
B: BLACK

1: PBT
2: PA6T
3: PA9T
4: LCP

Bill of materials:

3	HOUSING	LCP	1	UL94V-0	X. ±0.35	X.' ±2'	UNITS	mm	东莞市腾兴电子有限公司	
2	SHELL	COPPER ALLOY	1	PLATED NICKEL	.X ±0.3	.X' ±1'	MAT'L	SEE NOTE		TITLE: USB A/F 90度DIP 一型直脚无后盖 SMT (6.30mm)
1	TERMINAL	COPPER ALLOY	4	PLATED GOLD/TIN	.XXX ±0.15	.XXX'	FINISH	SEE NOTE		PART NO.: USAF-04*N-4*V602
NO	PARTS	MATERIAL	QTY	FINISHING	<small>THESE DRAWINGS AND SPECIFICATIONS ARE THE PROPERTY OF ACCURATE INNOTECH INC AND SHALL NOT BE REPRODUCED, COPIED OR USED IN ANY MANNER WITHOUT THE PRIOR WRITTEN CONSENT OF ACCURATE INNOTECH INC</small>		Q'TY	SEE NOTE		DR: <i>Ricky</i> 2014/04/10
									DWG NO.: All-V602	
									CHKD: <i>Ricky</i> 2014/04/10	
									APPD:	
									SCALE: 1:1	
									SHEET: 1/1	
									REV: B	
									CUSTOMER DRAWING	