

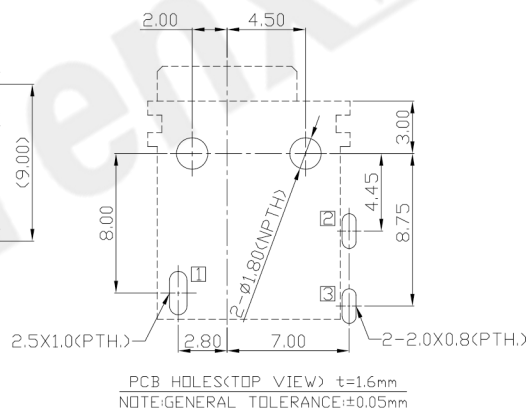

RoHS
Compliant
2002/95/EC

REV.	ECN.	NO.	APPD.

DIMENSIONS

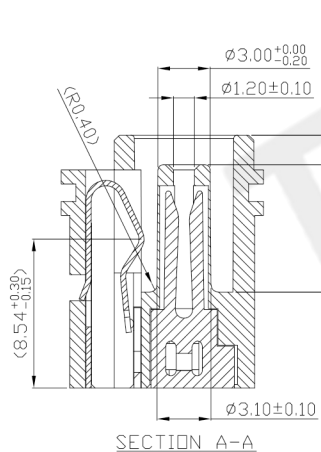
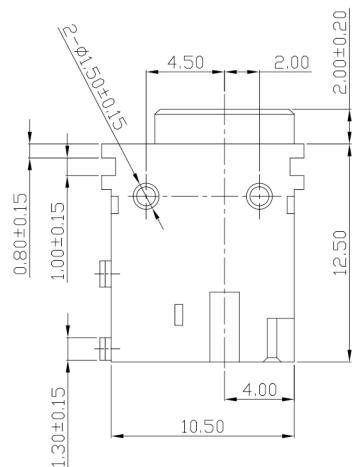
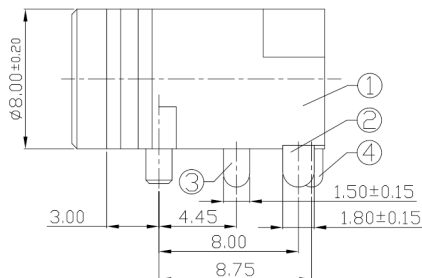
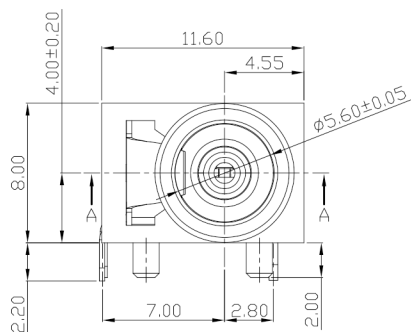

MODEL CODE:

- DCB0-00800- A D 9T BK I 0 1
 (1) (2) (3)(4) (5) (6) (7)(8) (9)
 (1):Series type:DIP DC POWER JACK.
 (2):Series No.
 (3):Schematic option: A , B
 (4):Center pin diameter:
 D=φ1.2
 (5):Material of housing:
 9T=PA9T , PB=PBT
 (6):Housing color:
 BK=Black
 (7):Terminal plating
 T=Tin(Sn)
 S=Silver(Ag)
 (8):Special option:
 0=No special option
 (9):Packing mode:
 1=Tape reel packing
 4=Bag packing

SPECIFICATION:

- Rating : DC 36V 5A;
- Contact resistance: ≤30mΩ;
After test: ≤50mΩ
- Insulation resistance: ≥100MΩ (DC500V);
After test: ≥50MΩ
- Withstand voltage: 500VAC ;
- Insertion and extraction force: 3-30N;
- life test: 5,000 cycles;
- Operation temperature range:-20°C~70°C;
- Preservative temperature range:-40°C~85°C;

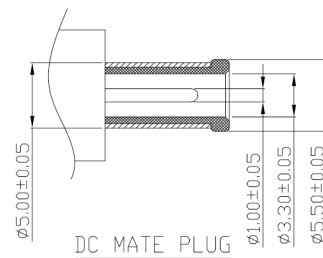
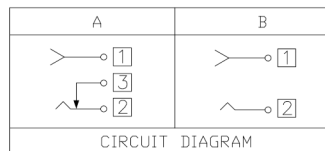

○: ITEM NO. □: TERMINAL NO.

NO.	PARTS	MATERIAL	Q'TY	FINISHING
④	Shunt terminal ③	Copper alloy	1	Tin/Silver plating
③	Tip spring ②	Copper alloy	1	Tin/Silver plating
②	Center pin ①	Copper alloy	1	Tin/Silver plating
①	Housing	See P/□ info	1	Black

TOLERANCE	ANGLES	UNITS	mm
.X ±0.50	X ±5°	MAT'L	SEE NOTE
.XX ±0.30	.X ±3°	FINISH	SEE NOTE
.XXX ±0.15	.XX ±2°	Q'TY	SEE NOTE

THESE DRAWINGS AND SPECIFICATIONS ARE THE PROPERTY OF ACCURATE INNO TECH INC AND SHALL NOT BE REPRODUCED, COPIED OR USED IN ANY MANNER WITHOUT THE PRIOR WRITTEN CONSENT OF ACCURATE INNO TECH INC.

东莞市腾兴电子有限公司			
TITLE: DIP DC POWER JACK		PART NO.: DCB0-00800	
DR: Ricky 2019/05/02		DWG NO.: AB0-00800	
CHKD: Ricky 2019/05/02		SCALE: 1:1	SHEET: 1/1
APPD:		REV.: A	CUSTOMER DRAWING