

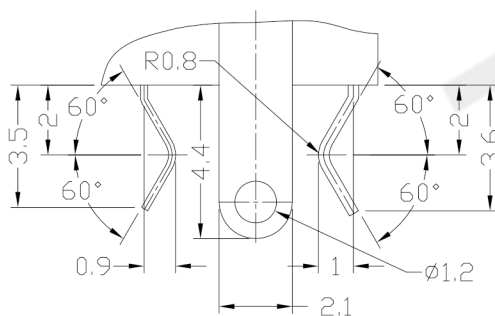

RoHS Compliant
2002/95/EC

REV.	ECN.	NO.	APPD.

DIMENSIONS

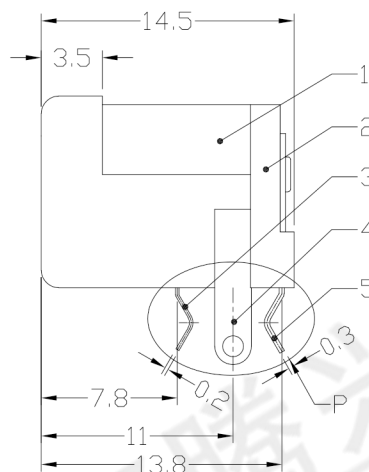
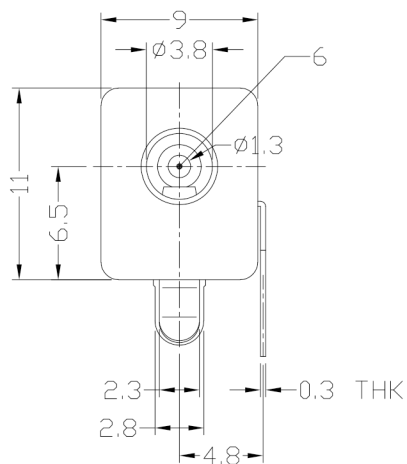

VIEW P
SCALE 5:1

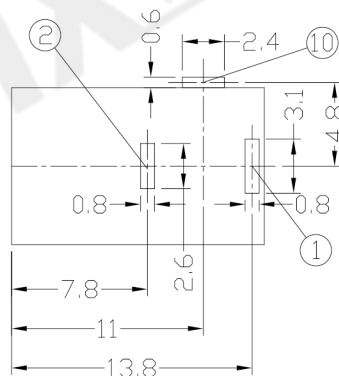

P.C.B LAYOUT
BOTTOM VIEW

MODEL CODE:

DCJ0-02420- A E PB BK S 0 4

(1) (2) (3)<4> (5) (6) (7)<8> (9)

(1):Series type:DIP DC POWER JACK.

(2):Series No.

(3):Schematic option: A

(4):Center pin diameter:
H=φ1.3

(5):Material of housing:
PB=PBT

(6):Housing color:
BK=Black

(7):Terminal plating
S=Silver(Ag)

(8):Special option:
0=No special option

(9):Packing mode:
4=Bag packing

Specification:

1.Rating :DC 30V 0.3A.

2.Contact resistance :≤100mΩ

3.Insulation resistance : ≥100MΩ (500VDC).

4.Withstanding voltage: 500VAC .

5.Insertion and extraction force: 0.3~3Kgs.

6.life test: 5000cycles min.

7.Operaton temperature range:-25°C~70°C

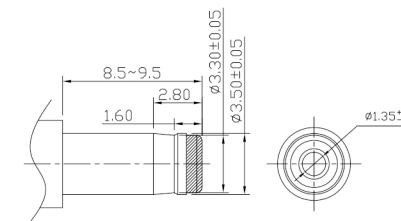
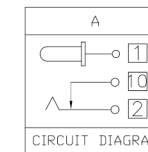

DC MATE PLUG

Bill of materials:

NO.	PARTS	MATERIAL	Q'TY	FINISHING
6	PLUG PIN	BRASS	1	Ni PLATED
5	CONTACT	BRASS STRIP	1	Ag PLATED OVER Ni PLATED
4	TERMINAL	BRASS STRIP	1	Ag PLATED OVER Ni PLATED
3	SPRING TERMINAL	SUS STRIP	1	Ag PLATED OVER Ni PLATED
2	COVER	PBT+94V0+F.G	1	BLACK
1	CASE	PBT+94V0+F.G	1	BLACK

GENERAL TOLERANCE	UNITS mm
WITHIN 1.5mm±0.1mm	MAT'L
OVER 1.5mm±0.2mm	SEE NOTE
THESE DRAWINGS AND SPECIFICATIONS ARE THE PROPERTY OF ACCURATE INNO TECH INC AND SHALL NOT BE REPRODUCED, COPIED OR USED IN ANY MANNER WITHOUT THE PRIOR WRITTEN CONSENT OF ACCURATE INNO TECH INC.	FINISH
	SEE NOTE
	Q'TY

DR: Ricky 2019/03/20	CHKD: Ricky 2019/03/20
APPD:	

东莞市腾兴电子有限公司			
TITLE: DIP DC POWER JACK		PART NO.: DCJ0-02420	
DR: Ricky 2019/03/20		DWG NO.: ADJ-02420	
SCALE	SHEET	REV.	CUSTOMER DRAWING
1:1	1/1	A	