

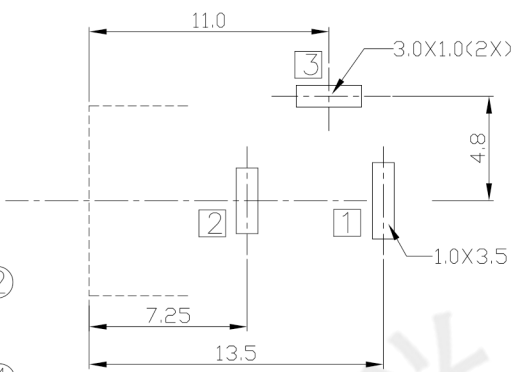

RoHS  
Compliant  
2002/95/EC

REV.	ECN.	NO.	APPD.

DIMENSIONS

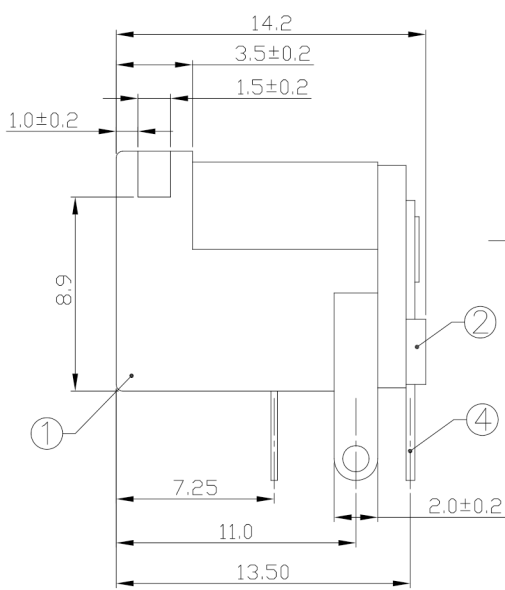
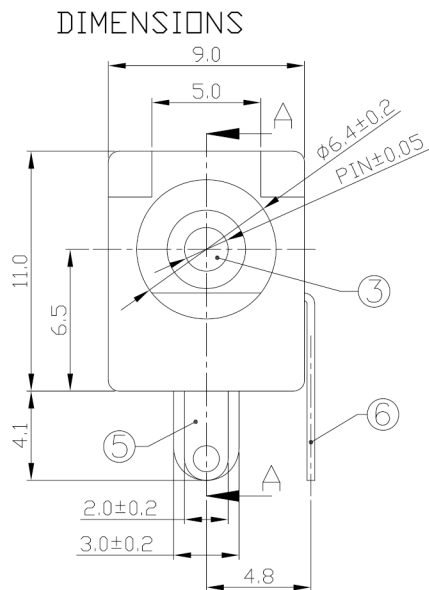

RECOMMENDED P.C.B. LAYOUT  
UNSPECIFIED TOLERANCE:±0.05  
(BOTTOM VIEW)

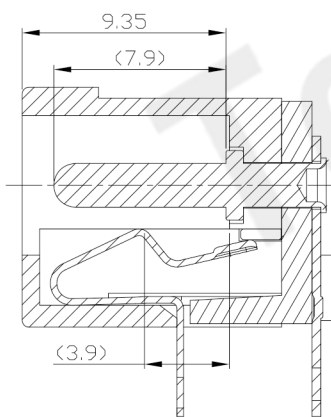

SECTION A-A

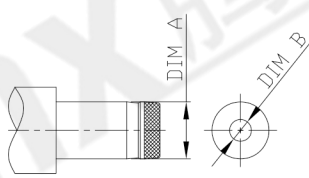

DC MATE PLUG

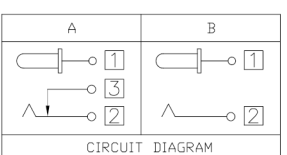

CIRCUIT DIAGRAM

Model No.	H	I	J
CENTER PIN	φ2.0	φ2.35	φ2.5
DIM A	φ5.5±0.05	φ5.5±0.05	φ5.5±0.05
DIM B	φ2.05 <sup>+0.10</sup> <sub>-0.00</sub>	φ2.40 <sup>+0.10</sup> <sub>-0.00</sub>	φ2.55 <sup>+0.10</sup> <sub>-0.00</sub>

MODEL CODE:

DCB0-005BY- A □ PB BK T 0 4

- (1): Series type: DIP DC POWER JACK.
- (2): Series No.
- (3): Schematic option: A , B
- (4): Center pin diameter:  
H=φ2.0 , I=φ2.35 , J=φ2.5
- (5): Material of housing:  
PB=PBT
- (6): Housing color:  
BK=Black  
2A=Red(0350)=PBT4815  
2R=Red(0046)=XH1033)=PBT4815  
4H=Yellow(0039)=XH1029)=PBT4815  
4N=Yellow(0080)=PBT4815  
9A=White(0100)=XH1013)=PBT4815
- (7): Terminal plating  
T=Tin(Sn)
- (8): Special option:  
0=Black cover
- (9): Packing mode:  
4=Bag packing

Specification:

- 1.Rating : DC 20V 4A.
- 2.Contact resistance : ≤30mΩ  
After test: ≤50mΩ
- 3.Insulation resistance : ≥100MΩ (500VDC).  
After test: ≥50MΩ
- 4.Withstanding voltage: 500VAC .
- 5.Insertion and extraction force: 3N~30N.
- 6.life test: 5000cycles min.
- 7.Operation temperature range:-20℃~70℃.
- 8.Preservative temperature range:-40℃~85℃.

○: ITEM NO. □: TERMINAL NO.

NO.	PARTS	MATERIAL	Q'TY	FINISHING	TOLERANCE	ANGLES	UNITS
⑥	Shunt terminal	Brass t=0.35	1	Tin plating	±0.3	±2°	mm
⑤	Tip spring	Phosphor bronze t=0.30	1	Tin plating			MAT'L
④	Center pin terminal	Brass t=0.4	1	Tin plating			SEE NOTE
③	Center pin	Brass	1	CuSn plating			FINISH
②	Cover	Thermoplastic	1	See P/N ordering info			SEE NOTE
①	Housing	Thermoplastic	1	See P/N ordering info			Q'TY

THESE DRAWINGS AND SPECIFICATIONS ARE THE PROPERTY OF ACCURATE INNOVATECH INC AND SHALL NOT BE REPRODUCED, COPIED OR USED IN ANY MANNER WITHOUT THE PRIOR WRITTEN CONSENT OF ACCURATE INNOVATECH INC.

东莞市腾兴电子有限公司

TITLE: DIP DC POWER JACK		PART NO.: DCB0-005BY	
DR: Ricky 2019/03/05		DWG NO.: AB0-005BY	
CHKD: Ricky 2019/03/05		SCALE	SHEET
APPD:		1:1	1/1
		REV.	CUSTOMER DRAWING
		A	