

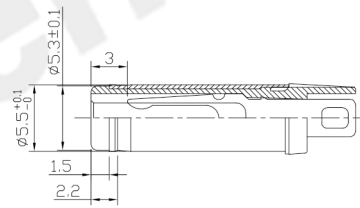

RoHS Compliant  
2002/95/EC

### DIMENSIONS

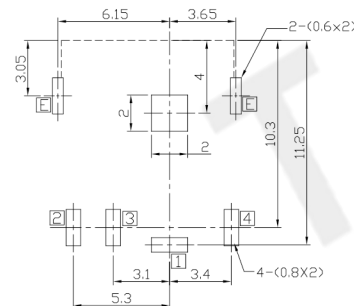
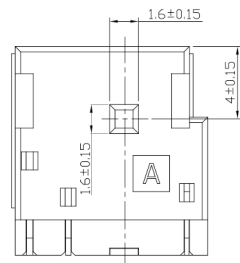
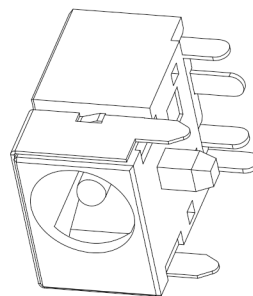
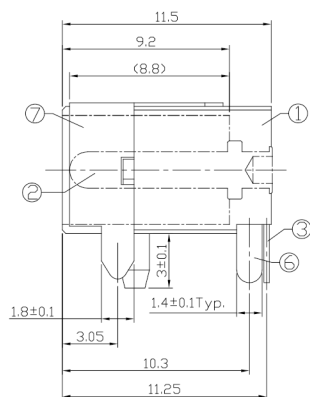
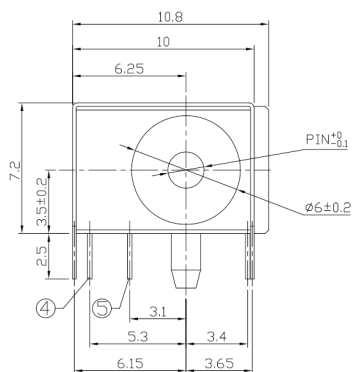

DC MATE PLUG

PCB HOLES(BOTTOM VIEW) t=1.6mm  
NOTE:GENERAL TOLERANCE:±0.05mm  
(BOTTOM VIEW)

### MODEL CODE:

- DCB0-0044C- C □ PB BK S 0 4  
(1) (2) (3)(4) (5) (6) (7)(8) (9)  
(1):Series type:DIP DC POWER JACK.  
(2):Series No.  
(3):Schematic option: A , B , C , D  
(4):Center pin diameter:  
G=φ1.65 , H=φ2.0 , J=φ2.5  
(5):Material of housing:  
PB=PBT , 9T=PA9T , 10=PA10T  
(6):Housing color:  
BK=Black (Standard)  
(7):Terminal plating  
S=Silver(Ag)(Standard)  
(8):Special option:  
0=No special option  
H=Housing is Halogen Free  
(9):Packing mode:  
1=Reel packing  
3=Plastic box packing  
4=Bag packing

### SPECIFICATION:

- Rating : DC 25V 3A;
- Contact resistance: ≤30mΩ;  
After test:≤50mΩ
- Insulation resistance: ≥100MΩ (DC500V);  
After test:≥50MΩ
- Withstand voltage: 500VAC ;
- Insertion and extraction force: 3-30N;
- life test: 5,000 cycles;
- Operation temperature range:-20°C~70°C;
- Preservative temperature range:-40°C~85°C;

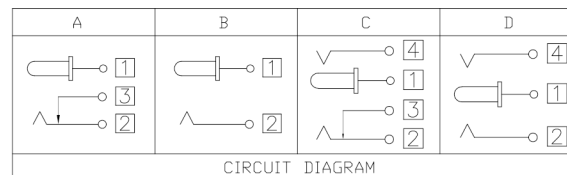

Model No.	G	H	J
CENTER PIN	φ1.65	φ2.0	φ2.5

○: ITEM NO. □: TERMINAL NO.

NO.	PARTS	MATERIAL	Q'TY	FINISHING	TOLERANCE	ANGLES	UNITS	mm
7	Ground shield	Brass t=0.2	1	Nickel plating	±0.3	±2°	MAT'L	SEE NOTE
6	Tip spring-2	Phosphor Bronze t=0.25	1	Silver plating				
5	Shunt Terminal	Brass t=0.3	1	Silver plating	SEE NOTE	FINISH	SEE NOTE	Q'TY
4	Tip spring-1	Phosphor Bronze t=0.3	1	Silver plating				
3	Center pin terminal	Brass t=0.3	1	Silver plating	SEE NOTE	FINISH	SEE NOTE	Q'TY
2	Center pin	Copper alloy	1	Nickel plating				
1	Housing	PBT/PA9T/PA10T	1	Black	SEE NOTE	FINISH	SEE NOTE	Q'TY
0	PARTS	MATERIAL	Q'TY	FINISHING				

THESE DRAWINGS AND SPECIFICATIONS ARE THE PROPERTY OF ACCURATE INNOVATECH INC AND SHALL NOT BE REPRODUCED, COPIED OR USED IN ANY MANNER WITHOUT THE PRIOR WRITTEN CONSENT OF ACCURATE INNOVATECH INC.

东莞市腾兴电子有限公司

TITLE: DIP DC POWER JACK PART NO.: DCB0-0044C

DR: Ricky 2019/04/29 DWG NO.: AB0-0044C

CHKD: Ricky 2019/04/29 SCALE SHEET REV. CUSTOMER DRAWING  
1:1 1/1 A

