

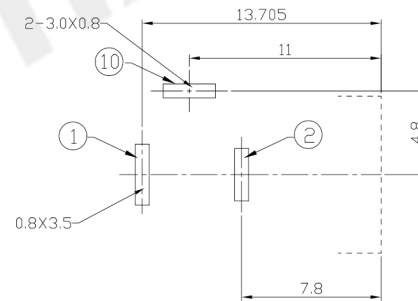

RoHS Compliant
2002/95/EC

REV.	ECN. NO.	APPD.

DIMENSIONS

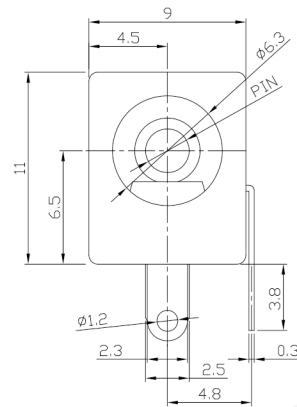
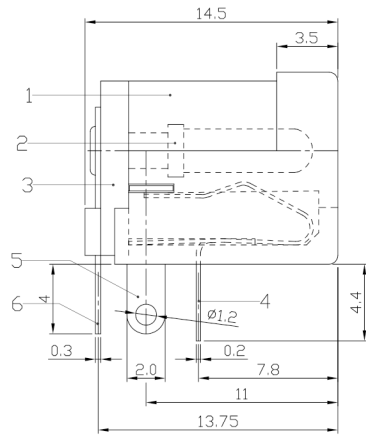

P.C.B LAYOUT

MODEL CODE:

DCE0-02102- A □ 66 BK S 0 4

(1) (2) (3)<4> (5) (6) (7)<8> (9)

(1):Series type:DIP DC POWER JACK.

(2):Series No.

(3):Schematic option: A

(4):Center pin diameter:

H=φ2.0, I=φ2.35, J=φ2.5

(5):Material of housing:

66=PA66

(6):Housing color:

BK=Black

(7):Terminal plating

S=Silver(Ag)

(8):Special option:

0=No special option

(9):Packing mode:

4=Bag packing

Specification:

1.Rating :DC 30V 0.3A.

2.Contact resistance :≤100mΩ

3.Insulation resistance : ≥100MΩ (500VDC).

4.Withstanding voltage: 500VAC .

5.Insertion and extraction force: 0.3~3Kgs.

6.life test: 5000cycles min.

7.Operation temperature range:-25°C~85°C

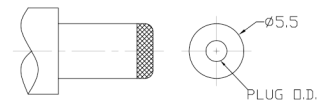
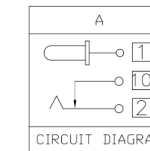

DC MATE PLUG

Model No.	H	I	J
CENTER PIN	φ2.0	φ2.35	φ2.5
PLUG O.D.	2.05 ^{+0.10} _{-0.00}	2.40 ^{+0.10} _{-0.00}	2.55 ^{+0.10} _{-0.00}

Bill of materials:

NO.	PARTS	MATERIAL	Q'TY	FINISHING
6	TERMINAL	BRASS STRIP	1	Ag PLATED
5	TERMINAL	BRASS STRIP	1	Ag PLATED
4	SPRING TERMINAL	SUS	1	Ag PLATED
3	COVER	PA6T/NYLON+F.G	1	BLACK
2	PLUG PIN	BRASS	1	Ni PLATED
1	CASE	PA6T/NYLON+F.G	1	BLACK

GENERAL TOLERANCE	UNITS mm
WITHIN 1.5mm±0.1mm	MAT'L
OVER 1.5mm±0.2mm	SEE NOTE
	FINISH
	SEE NOTE
	Q'TY

东莞市腾兴电子有限公司			
TITLE: DIP DC POWER JACK		PART NO.: DCE0-02102	
DR: Ricky 2019/03/18		DWG NO.: AZJ-02102	
CHKD: Ricky 2019/03/18		SCALE	SHEET
APPD:		1:1	1/1
		REV. A	CUSTOMER DRAWING

THESE DRAWINGS AND SPECIFICATIONS ARE THE PROPERTY OF ACCURATE INNOVATECH INC AND SHALL NOT BE REPRODUCED, COPIED OR USED IN ANY MANNER WITHOUT THE PRIOR WRITTEN CONSENT OF ACCURATE INNOVATECH INC.

