

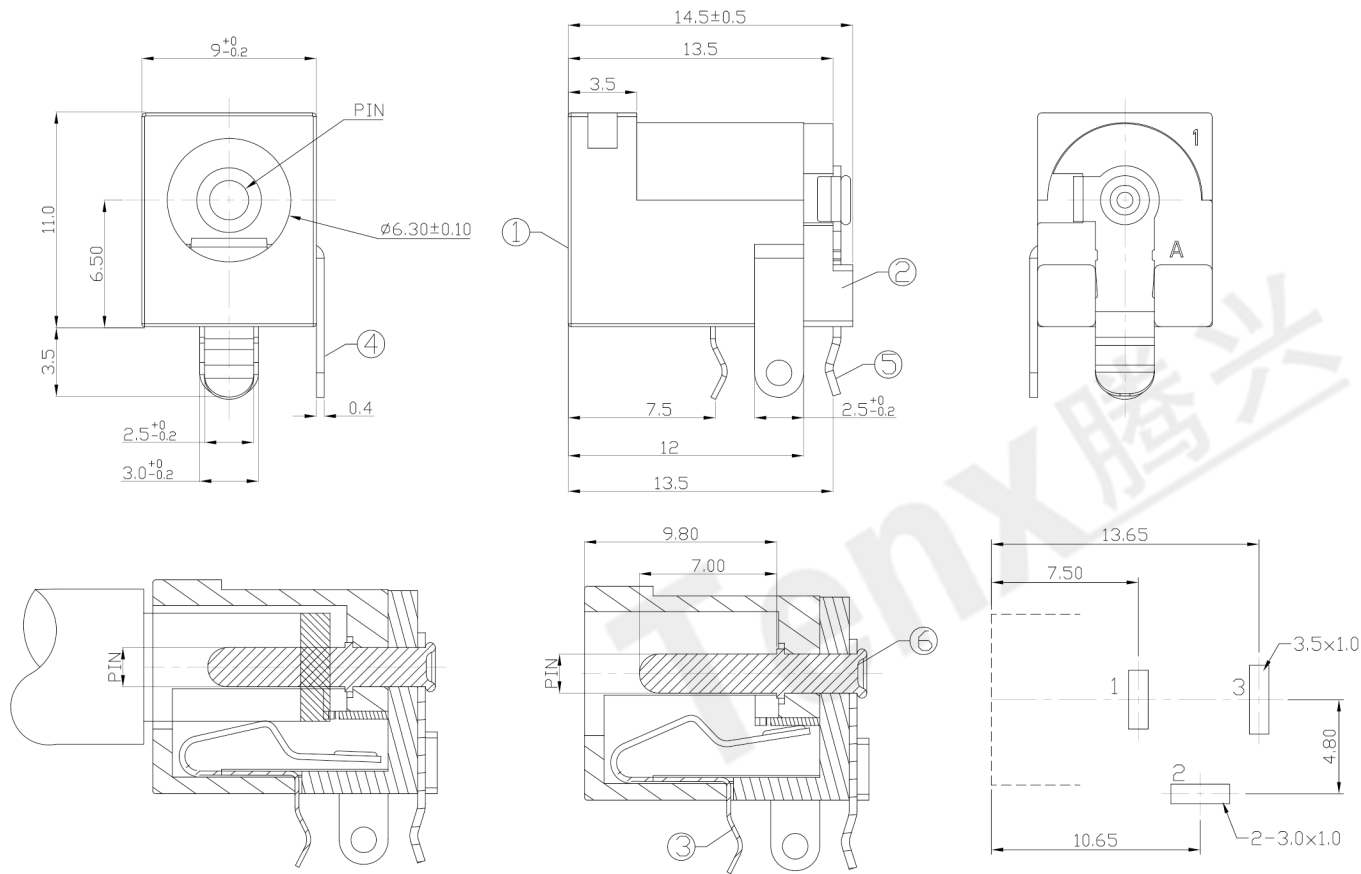

RoHS
Compliant
2002/95/EC

REV.	ECN.	NO.	APPD.

DIMENSIONS



MODEL CODE:
DCS0-0203E- A □ PB BK S 0 4
(1) (2) (3)(4) (5) (6) (7)(8) (9)
(1):Series type:DIP DC POWER JACK.
(2):Series No.
(3):Schematic option: A
(4):Center pin diameter:
G=φ1.65 , H=φ2.0 , J=φ2.5
(5):Material of housing:
PB=PBT
(6):Housing color:
BK=Black
(7):Terminal plating
S=Silver(Ag)
(8):Special option:
0=No special option
(9):Packing mode:
4=Bag packing

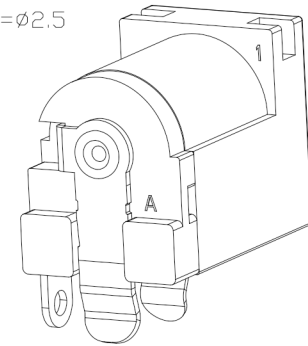

Specification:
1.Rating :DC 30V 1A.
2.Contact resistance :≤100mΩ
3.Insulation resistance :≥100MΩ (DC250V).
4.Withstanding voltage: 500VAC .
5.Insertion and extraction force: 3~30N.
6.life test: 5000cycles min.
7.Operaton temperature range:-25°C~85°C

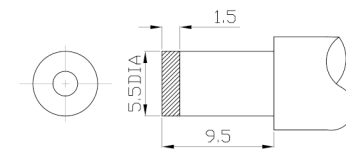
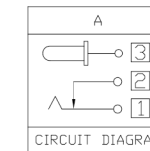

P.C.B LAYOUT
TOP VIEW

Model No.	G	H	J
CENTER PIN	φ1.65	φ2.0	φ2.5

Bill of materials:

NO.	PARTS	MATERIAL	Q'TY	FINISHING
6	PIN	BRASS	1	Ni-Plating
5	FLAP FOOT	BRASS	1	Ag-Plating
4	CURVE PIECE	BRASS	1	Ag-Plating
3	SPRING PIECE	BRONZE	1	Ag-Plating
2	COVER	PBT	1	UL94V-0 BLACK
1	HOUSING	PBT	1	UL94V-0 BLACK

TOLERANCE	ANGLES	UNITS	mm
.X ± 0.3	X°,±5°	MAT'L	SEE NOTE
.XX ± 0.2	.X°±3°	FINISH	SEE NOTE
.XXX ± 0.1		Q'TY	

东莞市腾兴电子有限公司			
TITLE: DIP DC POWER JACK		PART NO.: DCS0-0203E	
DR: Ricky 2019/03/21		DWG NO.: ASS-0203E	
CHKD: Ricky 2019/03/21		SCALE: 1:1	SHEET: 1/1
APPD:		REV: A	CUSTOMER DRAWING

THESE DRAWINGS AND SPECIFICATIONS ARE THE PROPERTY OF ACCURATE INNO TECH INC AND SHALL NOT BE REPRODUCED, COPIED OR USED IN ANY MANNER WITHOUT THE PRIOR WRITTEN CONSENT OF ACCURATE INNO TECH INC.