

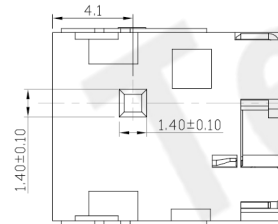

RoHS  
Compliant  
2002/95/EC

REV.	ECN.	NO.	APPD.

### DIMENSIONS

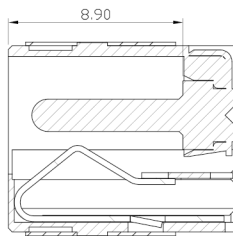
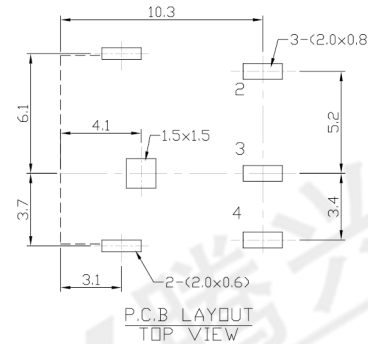
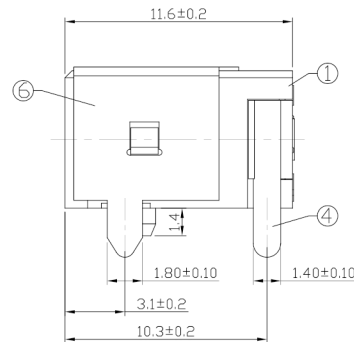
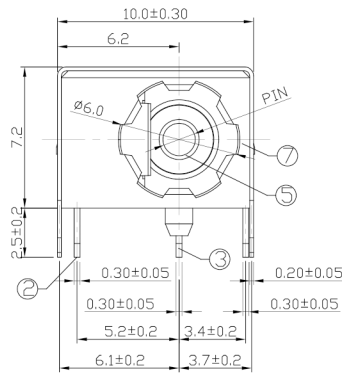

### MODEL CODE:

DCS0-0217B- A □ 9T BK S 0 3

(1) (2) (3)(4) (5) (6) (7)(8) (9)

(1):Series type:DIP DC POWER JACK.

(2):Series No.

(3):Schematic option: A

(4):Center pin diameter:

G=φ1.65 , H=φ2.0 , J=φ2.5

(5):Material of housing:

9T=PA9T

(6):Housing color:

BK=Black

(7):Terminal plating

S=Silver(Ag)

(8):Special option:

0=No special option

(9):Packing mode:

1=Reel packing

3=Plastic box packing

### Specification:

1.Rating :DC 24V 5A.

2.Contact resistance :≤50mΩ

3.Insulation resistance :≥100MΩ (DC500V).

4.Withstanding voltage :500VAC .

5.Insertion and extraction force :3~30N.

6.life test :5000cycles min.

7.Operation temperature range:-25°C~85°C

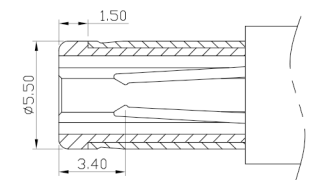
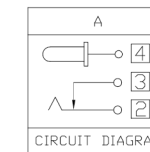

DC MATE PLUG

Model No.	G	H	J
CENTER PIN	φ1.65	φ2.0	φ2.5

### Bill of materials:

NO.	PARTS	MATERIAL	Q'TY	FINISHING	TOLERANCE	ANGLES	UNITS	mm
7	COVER	SUS301	1	Ni 60U" Min	.X ± 0.3	X°,±5°	MAT'L	
6	CONTACT FOOT	C2680	1	Tin 100U" Min	.XX ± 0.2	.X°±3°	SEE NOTE	
5	PIN	C2680	1	U" MinNi 60	.XXX ± 0.1		FINISH	
4	CONTACT FOOT	C2680	1	Ag 10U"Min			SEE NOTE	
3	CURVE PIECE	C2680	1	Ag 10U"Min			Q'TY	
2	SPRING PIECE	C5210	1	Ag 10U"Min				
1	HOUSING	PA9T	1	Black				

THESE DRAWINGS AND SPECIFICATIONS ARE THE PROPERTY OF ACCURATE INNOVATECH INC AND SHALL NOT BE REPRODUCED, COPIED OR USED IN ANY MANNER WITHOUT THE PRIOR WRITTEN CONSENT OF ACCURATE INNOVATECH INC.

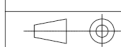

### 东莞市腾兴电子有限公司

TITLE: DIP DC POWER JACK		PART NO.: DCS0-0217B	
DR: Ricky 2019/03/21		DWG NO.: ASS-0217B	
CHKD: Ricky 2019/03/21	SCALE: 1:1	SHEET: 1/1	REV: A
APPD:	CUSTOMER DRAWING		