

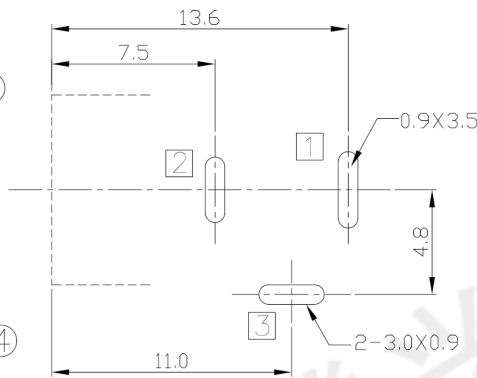

RoHS Compliant
2002/95/EC

DIMENSIONS

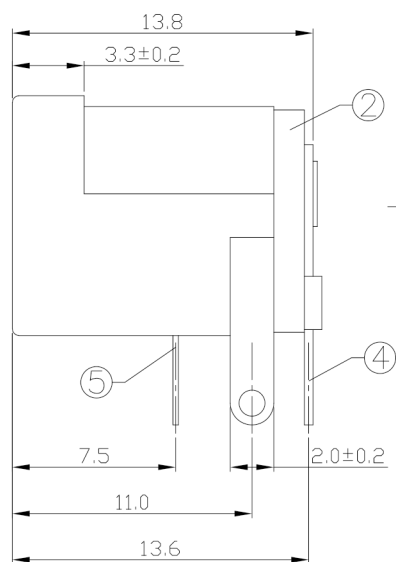
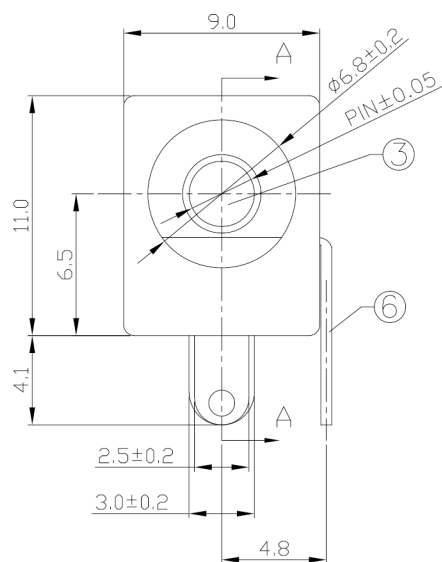

RECOMMENDED P.C.B. LAYOUT
UNSPECIFIED TOLERANCE:±0.05
(TOP VIEW)

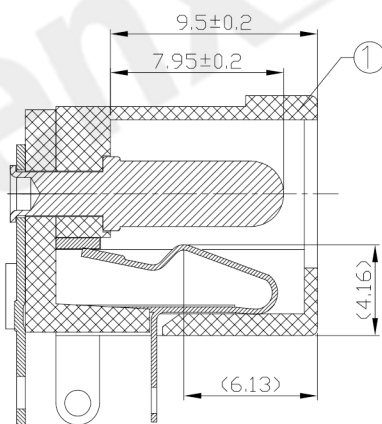

SECTION A-A

- MODEL CODE:
DCB0-0005F- A □ PB BK T 0 4
(1) (2) (3)(4) (5) (6) (7)(8) (9)
- (1):Series type:DIP DC POWER JACK.
 - (2):Series No.
 - (3):Schematic option: A , B
 - (4):Center pin diameter:
H=φ2.0 , J=φ2.5 , K=φ3.0 , L=φ3.2
 - (5):Material of housing:
PB=PBT(Standard) , 66=PA66
6T=PA6T
 - (6):Housing color:
BK=Black , 9A=White(0100=PBT)
 - (7):Terminal plating
T=Tin(Sn)
 - (8):Special option:
0=Center pin is Circle needle
&Housing is Halogen
1=Center pin is Even needle
&Housing is Halogen
H=Center pin is Circle needle
&Housing is Halogen Free
 - (9):Packing mode:
4=Bag packing

- Specification:
- 1.Rating :DC 20V 4A.
 - 2.Contact resistance :≤30mΩ
After test:≤50mΩ
 - 3.Insulation resistance : ≥100MΩ (500VDC).
After test:≥50MΩ
 - 4.Withstanding voltage: 500VAC .
 - 5.Insertion and extraction force: 3N~30N.
 - 6.life test: 5000cycles min.
 - 7.Operation temperature range:-20℃~70℃.
 - 8.Preservative temperature range:-40℃~85℃.

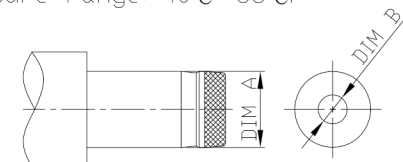
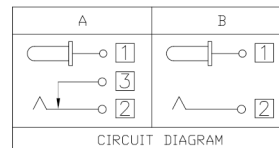

Model No.	H	J	K	L
CENTER PIN	φ2.0	φ2.5	φ3.0	φ3.2
DIM A	φ5.5±0.05	φ5.5±0.05	φ6.5±0.05	φ6.5±0.05
DIM B	φ2.05 ^{+0.10} _{-0.00}	φ2.55 ^{+0.10} _{-0.00}	φ3.05 ^{+0.10} _{-0.00}	φ3.25 ^{+0.10} _{-0.00}

DC MATE PLUG

○: ITEM NO. □: TERMINAL NO.

NO.	PARTS	MATERIAL	Q'TY	FINISHING	TOLERANCE	ANGLES	UNITS
⑥	Shunt terminal ③	Copper Alloy	1	Tin plating			mm
⑤	Tip spring ②	Copper Alloy	1	Tin plating	±0.3	±2°	MAT'L
④	Center pin terminal ①	Copper Alloy	1	Tin plating			SEE NOTE
③	Center pin	Copper Alloy	1	CuSn plating			FINISH
②	Cover	Thermoplastic	1	Black			SEE NOTE
①	Housing	Thermoplastic	1	See P/N ordering info			Q'TY
					THESE DRAWINGS AND SPECIFICATIONS ARE THE PROPERTY OF ACCURATE INNO TECH INC AND SHALL NOT BE REPRODUCED, COPIED OR USED IN ANY MANNER WITHOUT THE PRIOR WRITTEN CONSENT OF ACCURATE INNO TECH INC.		

东莞市腾兴电子有限公司

TITLE: DIP DC POWER JACK	PART NO.: DCB0-0005F
DR: Ricky 2019/03/06	DWG NO.: AB0-0005F
CHKD: Ricky 2019/03/06	SCALE SHEET REV. CUSTOMER DRAWING
APPD:	1:1 1/1 A