

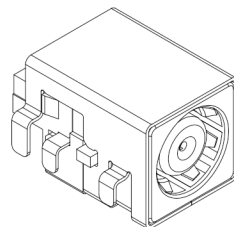

RoHS  
Compliant  
2002/95/EC

Halogen Free

DIMENSIONS

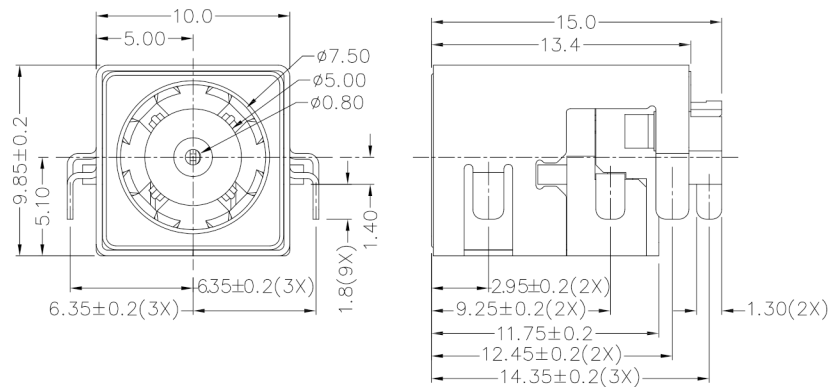

MODEL CODE:

DCT0-106DHS- W M 10 BK G 0 1

- (1):Series type:SMD DC POWER JACK.
- (2):Series No.
- (3):Schematic option: W
- (4):Center pin diameter:  
M=0.6mm
- (5):Material of housing:  
10=PA10T
- (6):Housing color:  
BK=Black
- (7):Terminal plating:  
G=Gold(Au)
- (8):Special option:  
0=No special option
- (9):Packing mode:  
1=Reel packing

Specification:

- 1.Rating : 8A/20V DC Max.
- 2.Contact resistance :  $\leq 30m\Omega$   
After test: $\leq 60m\Omega$
- 3.Insulation resistance :  $\geq 100M\Omega$  (DC500V).  
After test: $\geq 50M\Omega$
- 4.Withstanding voltage : 500VAC.
- 5.Insertion and extraction force : 0.3~3Kgs.
- 6.Life test : 5,000cycles min.
- 7.Operation temperature range:-25℃~85℃.

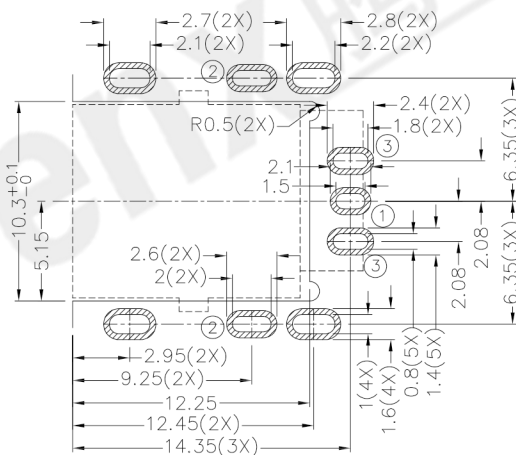
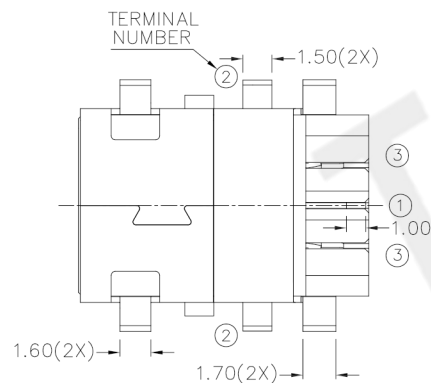

RECOMMENDED P.C.B. LAYOUT  
TOLERANCE:±0.05  
(TOP VIEW)

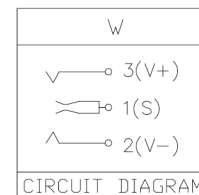

MODEL NO.	M
CENTER PIN	0.6mm

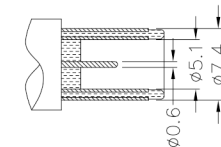

DC MATE PLUG

Bill of materials:

NO.	PARTS	MATERIAL	Q'TY	FINISHING
6	TERMINAL 1	COPPER ALLOY	1	GOLD PLATED
5	TERMINAL 2	COPPER ALLOY	1	GOLD PLATED
4	TERMINAL 3	COPPER ALLOY	1	GOLD PLATED
3	SHIELD	BRASS	1	NICKEL PLATED
2	STOPPER	PA10T	1	UL94V-0
1	HOUSING	PA10T	1	UL94V-0

TOLERANCE	ANGLES	UNITS	mm
±0.3	±2°	MAT'L	
		SEE NOTE	
		FINISH	
		SEE NOTE	
		Q'TY	

THESE DRAWINGS AND SPECIFICATIONS ARE THE PROPERTY OF ACCURATE INNOVATION INC AND SHALL NOT BE REPRODUCED, COPIED OR USED IN ANY MANNER WITHOUT THE PRIOR WRITTEN CONSENT OF ACCURATE INNOVATION INC.

东莞市腾兴电子有限公司

TITLE: SMD DC POWER JACK		PART NO.: DCT0-106DHS	
DR: Ricky 2018/10/09		DWG NO.: AT0-106DHS	
CHKD: Ricky 2018/10/09		SCALE	SHEET
APPD:		1:1	1/1
		REV.	CUSTOMER DRAWING
		A	