

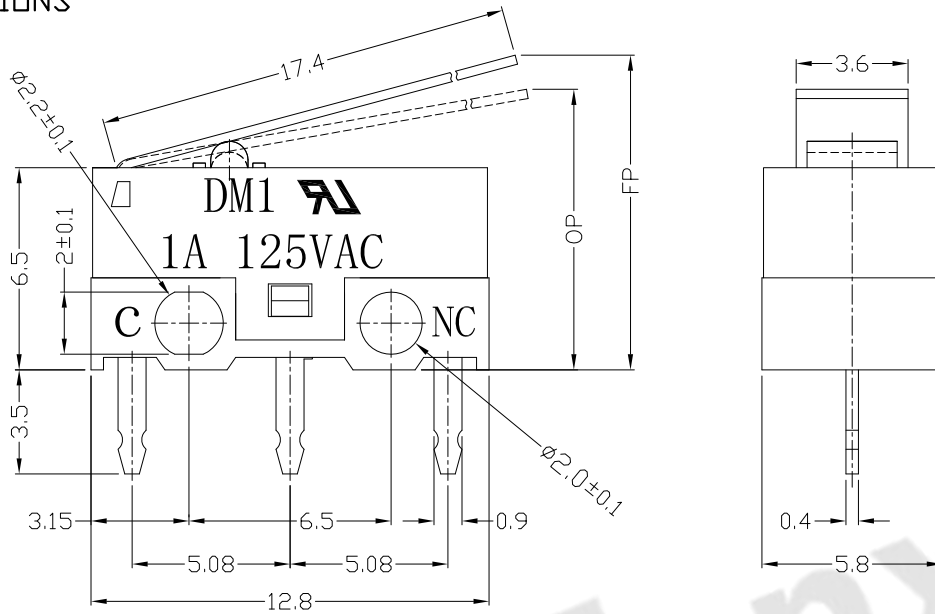

RoHS
Compliant
2002/95/EC

REV.	ECN.	NO.	APPD.

DIMENSIONS



1.Functional spec

1.1 Rated Voltage	125VAC/DC5V
1.2 Rated Current	1A/30mA
1.3 Contact Resistance	≤100mΩ(Initial value)
1.4 Operating Force	25±15gf 30±15gf
1.5 Bounce Time	
1.6 Free Position	11.0±1.0mm
1.7 Operating Position	9.2±1.0mm
1.8 Position Travel	
1.9 Return Force	

MODEL CODE

DM 1-03X-XX-3
1 2 3 4 5 6

- Series : DM
- Current Rating : 1=1A 125VAC ; 30mA DC5V
- Actuator : 00=non-lever 01-99=Lever
- Termination : see chart (P/C/D/T/N)
- Operating Force : see chart
- Button colour : 3=white
- Cover type : No-0=have two lines

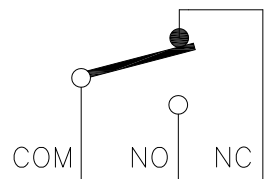

CIRCUIT DIAGRAM

2.Reliable Rating

2.1 Mechanical Life	1,000,000 CYCLES
2.2 Electrical Life	10,000 CYCLES
2.3 Insulation Resistance	≥100MΩ DC500V
2.4 Withstand Voltage	AC500V 1 minute
2.5 Soldering Technic	Hand Soldering
2.6 Operating Temper	-25°C ~ +65°C
2.7 Ambient Humidity Used	<85%RH

Tolerance:±0.2		UNITS	东莞市腾兴电子有限公司				
		mm					
		MAT'L	SEE NOTE		PART NO.:		
		FINISH	SEE NOTE		DM1-03P-XX-3		
		Q'TY	DR: Ricky 2017/2/17		DWG NO.:		
			CHKD: Ricky 2017/2/17		ATD-03X-XX-3		
THESE DRAWINGS AND SPECIFICATIONS ARE THE PROPERTY OF ACCURATE INNOTECH INC AND SHALL NOT BE REPRODUCED, COPIED OR USED IN ANY MANNER WITHOUT THE PRIOR WRITTEN CONSENT OF ACCURATE INNOTECH INC.			APPD:	SCALE	SHEET	REV.	CUSTOMER DRAWING
				1:1	1/2	A	



RoHS
Compliant
2002/95/EC

REV.	ECN.	NO.	APPD.

Terminal Type

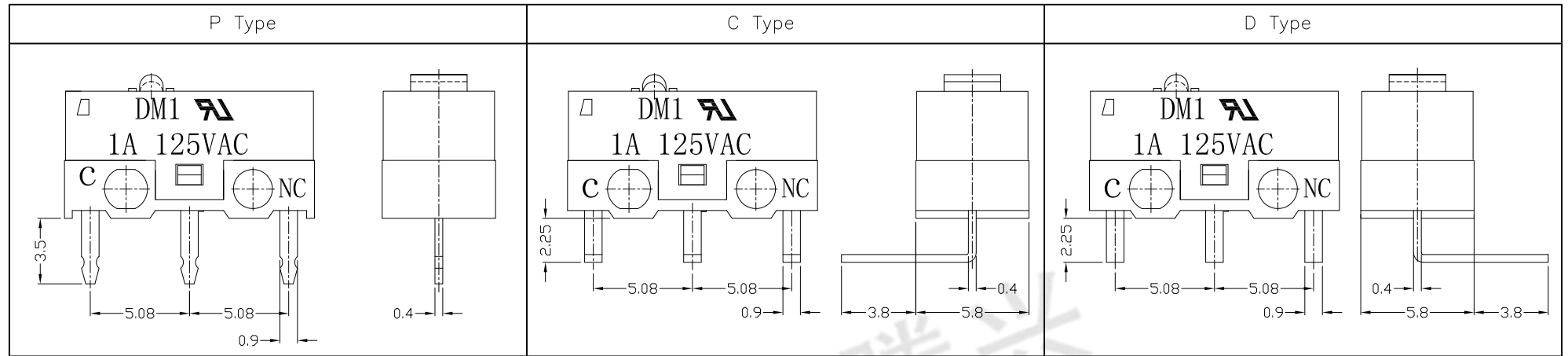

Structure chart

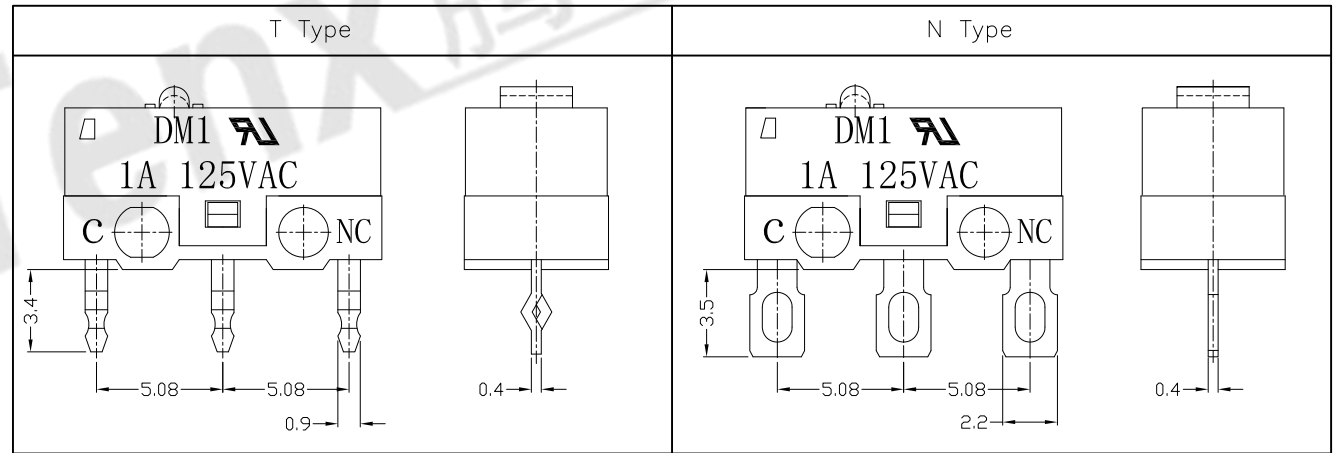
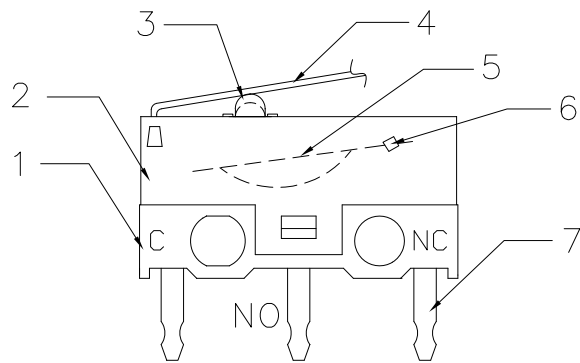

Material list

NO.	PARTS	MATERIAL	Q'TY	FINISHING
8				
7	Terminal	C2680	3	
6	Contact	Silver alloy	1	
5	Spring Plate	C1720	1	
4	Lever	SUS301	1	
3	Button	PBT	1	WHITE
2	Case	PBT	1	BLACK
1	Base	PBT	1	WHITE

Tolerance: ±0.2		UNITS	东莞市腾兴电子有限公司			
		mm				
		MAT'L				
		SEE NOTE	TITLE: MICRO SWITCH DM SERIES		PART NO: DM1-03X-XX-3	
		FINISH	DR: Ricky 2017/2/17		DWG NO: ATD-03X-XX-3	
		SEE NOTE	CHKD: Ricky 2017/2/17			
		Q'TY	APPD:		SCALE	SHEET
					1:1	2/2
					REV.	CUSTOMER
					A	DRAWING

THESE DRAWINGS AND SPECIFICATIONS ARE THE PROPERTY OF ACCURATE INNOVATECH INC AND SHALL NOT BE REPRODUCED, COPIED OR USED IN ANY MANNER WITHOUT THE PRIOR WRITTEN CONSENT OF ACCURATE INNOVATECH INC.



RoHS
Compliant
2002/95/EC

REV.	ECN.	NO.	APPD.

DIMENSIONS

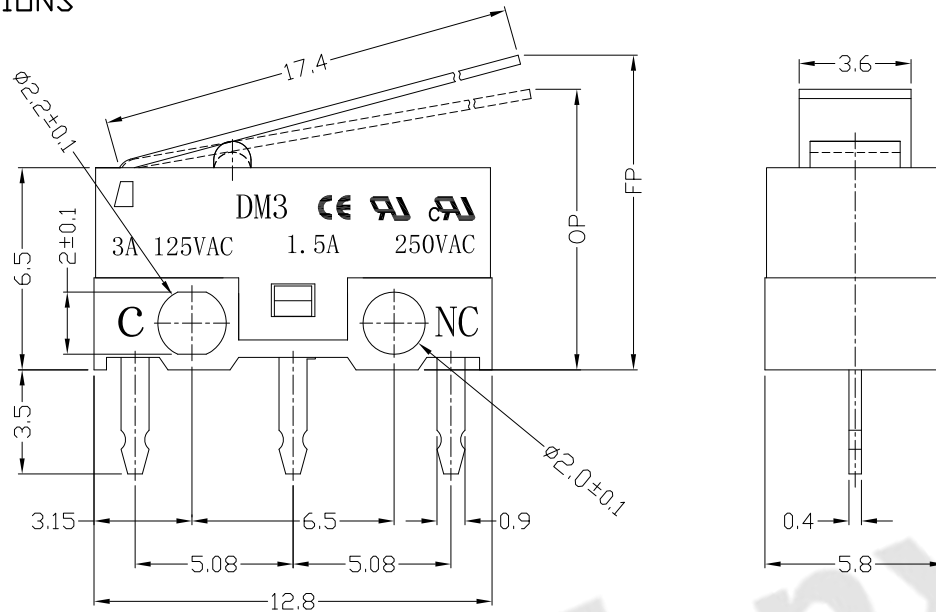

1.Functional spec

1.1 Rated Voltage	125VAC/250VAC
1.2 Rated Current	3A/1.5A
1.3 Contact Resistance	≤100mΩ(Initial value)
1.4 Operating Force	25±15gf 30±15gf
1.5 Bounce Time	
1.6 Free Position	11.0±1.0mm
1.7 Operating Position	9.2±1.0mm
1.8 Position Travel	
1.9 Return Force	

MODEL CODE

DM 3 - 03 X - XX - 6 - 0
1 2 3 4 5 6 7

- Series : DM
- Current Rating : 3=3A 125VAC ; 1.5A 250VAC
- Actuator : 00=non-lever 01-99=Lever
- Termination : see chart (P/C/D/T/N)
- Operating Force : see chart
- Button colour : 6=grey
- Cover type : 0=No two lines

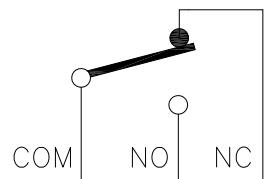

CIRCUIT DIAGRAM

2.Reliable Rating

2.1 Mechanical Life	1,000,000 CYCLES
2.2 Electrical Life	10,000 CYCLES
2.3 Insulation Resistance	≥100MΩ DC500V
2.4 Withstand Voltage	AC500V 1 minute
2.5 Soldering Technic	Hand Soldering
2.6 Operating Temper	-25°C ~ +65°C
2.7 Ambient Humidity Used	<85%RH

Tolerance:±0.2		UNITS	东莞市腾兴电子有限公司			
		mm				
		MAT'L	SEE NOTE		PART NO.: DM3-03P-XX-6-0	
		FINISH	SEE NOTE		DWG NO.: ATD-03X-XX-6-0	
THESE DRAWINGS AND SPECIFICATIONS ARE THE PROPERTY OF ACCURATE INNOTECH INC AND SHALL NOT BE REPRODUCED, COPIED OR USED IN ANY MANNER WITHOUT THE PRIOR WRITTEN CONSENT OF ACCURATE INNOTECH INC.		Q'TY	CHKD: Ricky 2017/2/21		SCALE: 1:1	
			APPD:		SHEET: 1/2	REV.: A
					CUSTOMER DRAWING	

