

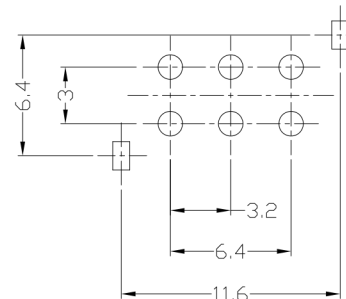

RoHS
Compliant
2002/95/EC

REV.	ECN.	NO.	APPD.

DIMENSIONS

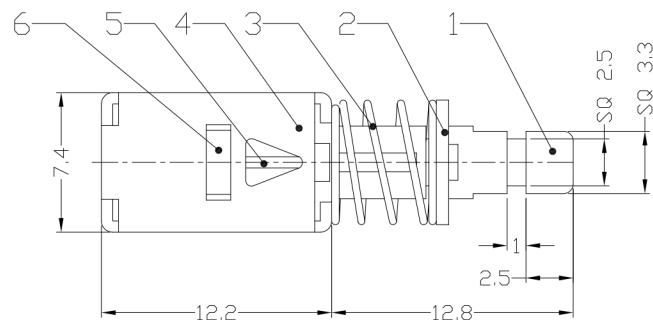

P.C.B LAYOUT
TOP VIEW

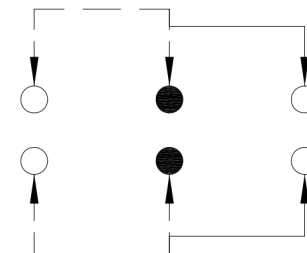

CIRCUIT DIAGRAM

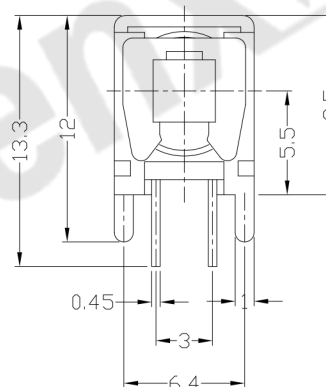
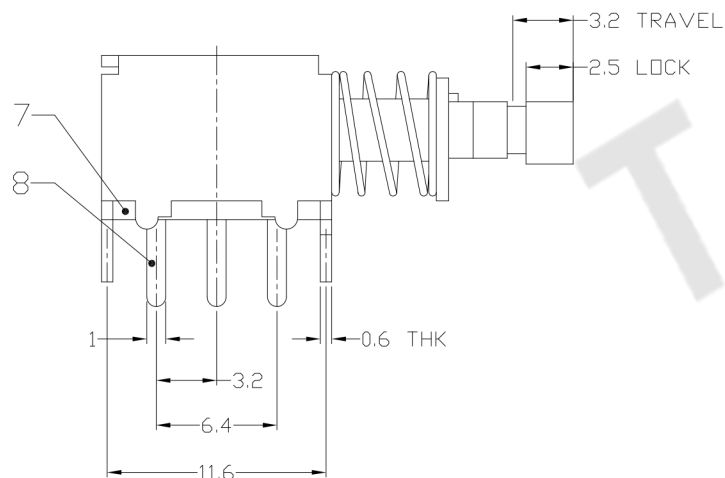

ELECTRO-MECHANICAL CHARACTERISTICS

Refer to additional specifications

RATING	DC50V 0.3A
CIRCUIT	2P2T
CONTACT RESISTANCE	30mΩ MAX.
TIMING	NON-SHORTING
OPERATING MODE	SELF-LOCK
STROKE	FULL 3.2mm LOCK 2.5mm
OPERATING FORCE	300±100gf
OPERATING LIFE(cycles)	10,000

9	CONTACT CLIP	PBS C5210-EH	2	Ag CLAD
8	TERMINAL	BRASS STRIP	6	<0.5 μm> Ag PLATED
7	BASE	PHENOLIC RESIN	1	NATURAL
6	SPRING PLATE	PBS STRIP	1	NATURAL
5	CAM STICK	PBS WIRE	1	Ni PLATED
4	FRAME	STEEL STRIP	1	Ni PLATED
3	SPRING	STEEL WIRE	1	Ni PLATED
2	BLOCK	STEEL STRIP	1	Ni PLATED
1	KNOB	POM/NYLON+F.G	1	BLACK/BLUE/YELLOW
NO.	PARTS	MATERIAL	Q'TY	FINISHING

WITHIN 1.5mm: ±0.1mm
OVER 1.5mm: ±0.2mm
UNITS mm
MAT'L SEE NOTE
FINISH SEE NOTE
Q'TY
THESE DRAWINGS AND SPECIFICATIONS ARE THE PROPERTY OF ACCURATE INNO TECH INC AND SHALL NOT BE REPRODUCED, COPIED OR USED IN ANY MANNER WITHOUT THE PRIOR WRITTEN CONSENT OF ACCURATE INNO TECH INC.

东莞市腾兴电子有限公司			
TITLE: PUSH SWITCH / HORIZONTAL	PART NO.: AP-22F44L		
DR: <i>Ricky</i> 2015/03/27	DWG NO.: ADJ-22F44		
CHKD: <i>Ricky</i> 2015/03/27	SCALE 2:1	SHEET 1/1	REV. A
APPD:	CUSTOMER DRAWING		